



SprayMate™ Plus

Auto Rate Controller

System Manual

SprayMate™ Plus

Auto Rate Controller

System Manual

The SprayMate™ Plus console is an enhanced version of the SprayMate™ II. The SprayMate™ Plus adds features to broaden the usage in the vegetable (fumigant) markets. The SprayMate™ Plus is an electronic control system that can help you achieve maximum yields and operate more cost-effectively by providing the information you need to maintain proper application rates of liquid chemicals and fertilizer. SprayMate™ Plus has been designed for easy installation and operation. However, since each installation will vary depending on your equipment, please take time to familiarize yourself with this manual and the actual components before beginning. Following the procedures described in this manual will ensure proper performance and help avoid problems or questions once you are in the field.

This manual is written for the SprayMate™ Plus, which may be used for either English, Metric or Turf measurement. Please read the manual carefully and follow the instructions as they apply to your usage.

If you do encounter a problem that cannot be corrected by reviewing this manual, consult your dealer or distributor, or contact a Micro-Trak® technician for assistance.

U.S. or Canada: Toll-free (800) 328-9613 or (507) 257-3600

Fax: 507-257-3001

www.micro-trak.com • trakmail@micro-trak.com



111 LeRay Avenue
Eagle Lake, MN 56024-9650

© 2021 • Micro-Trak® Systems, Inc.

Micro-Trak Systems, Inc. Limited Warranty Statement

Micro-Trak Systems, Inc. (herein "Seller") warrants to the original purchaser (herein "Buyer") that, if any product or part of the product (herein "Parts") proves to be defective in material or workmanship, upon inspection and examination by Seller, within three (3) years from the original date-of-purchase, and is returned to Seller with dated proof-of-purchase, transportation prepaid, within sixty (60) days after such defect is discovered, Seller will, at their option and sole discretion, either repair or replace said part, except that the warranty for expendable Parts, including but not limited to, light bulbs, batteries, hose and tubing, nuts, bolts, screws and other fasteners shall be thirty (30) days from the original date-of-purchase; and except that the warranty for Parts manufactured by someone other than the Seller, including but not limited to, shut-off valves, control (servo) valves, flowmeters, pressure sensors and regulators, pumps, motors, compressors, tanks and tank accessories, DGPS receivers and related repeater and base stations shall be one (1) year from the original date-of-purchase; and except that the warranty for Parts manufactured by someone other than the Seller, including but not limited to, memory cards and drives, mapping software, terminals, PC's, laptops, tablets and other computer devices shall be thirty (30) days from the original date-of-purchase. Any damage or failure to said part resulting from abuse, misuse, neglect, accidental or improper installation or maintenance, unauthorized modification, use with other parts and/or products, or attributable to acts of God, as determined solely by the Seller, will invalidate the warranty. Said part will not be considered defective if it substantially fulfills the performance specification. Buyer shall be responsible for all maintenance services, if any, all in strict accordance with the procedures outlined in the manual. The warranty does not include labor, installation, replacement parts or repairs, delivery of replacement parts or repairs or time and travel. Said warranty is non-transferable.

THE FOREGOING WARRANTY IS EXCLUSIVE AND IN LIEU OF ALL OTHER WARRANTIES OF MERCHANTABILITY, FITNESS FOR PURPOSE AND OF ANY OTHER TYPE, WHETHER EXPRESS OR IMPLIED. THE SELLER'S LIABILITY, WHETHER IN CONTRACT, IN TORT, UNDER ANY WARRANTY, IN NEGLIGENCE OR OTHERWISE, SHALL NOT EXCEED THE RETURN OF THE AMOUNT OF THE PURCHASE PRICE PAID BY THE BUYER, AND UNDER NO CIRCUMSTANCES SHALL THE SELLER BE LIABLE FOR SPECIAL, INDIRECT, CONSEQUENTIAL, INCIDENTAL OR PUNITIVE DAMAGES. SELLER NEITHER ASSUMES NOR AUTHORIZES ANYONE TO ASSUME FOR IT ANY OTHER OBLIGATION OR LIABILITY IN CONNECTION WITH SAID PART. NO ACTION, REGARDLESS OF FORM, ARISING OUT OF THE TRANSACTIONS UNDER THIS AGREEMENT MAY BE BROUGHT MORE THAN ONE (1) YEAR AFTER THE CAUSE OF ACTION HAS OCCURRED.

Buyer accepts these warranty terms and limitations unless the part is returned to Seller, via proper distribution channels and approved return authorization, with dated proof-of-purchase, transportation prepaid, within sixty (60) days from the date-of-purchase for refund of the purchase price.

Source Doc: MTS Warranty Statement 080120

MAIL and UPS:

**Micro-Trak® Systems, Inc.
ATTN: Service Department
111 LeRay Avenue
Eagle Lake, MN 56024-9650**

At Micro-Trak® Systems, we believe a product that delivers quality and performance at a reasonable cost is what is needed to help today's operator and the operator of the future compete in the world market.

It is our goal to provide operators with a line of electronic equipment that will help build and maintain an efficient and profitable operation that can be passed on to future generations.

We thank you for your purchase and hope that we can be of service to you in the future.

Micro-Trak® Systems, Inc.

Table of Contents

Micro-Trak® Warranty	3
Table of Contents	4
Component Parts and Hardware	5
System Overview	6
Wiring Diagram	7
Installation	8
Overview	8
Installation Steps	8
Mounting the Console	9
Electrical Installation	10
Branch Harness Connections	11
Speed Sensor Options	12
Optional Equipment - Switches	13
Plumbing Overview - Bypass	14
Plumbing Overview - Inline	15
System Components	16
Feature Summary	18
SprayMate™ Plus Console Function Summary	20
Calibration	21
Calibration Steps:	21
Restoring Default Calibration Values	21
Calibration Positions	22
Special Calibration	23
Operation	29
Manual Operation	29
Automatic Operation	29
Care and Maintenance of your SprayMate™ Plus	29
Console Controls	30
Additional System Features	31
Pre-Field System Checkout	32
Troubleshooting	33
Messages/Warnings	33
General	34
Checking Individual Components	35
Checking Console Inputs	36
Plumbing Troubleshooting Chart	37
Plumbing Guidelines	37
Appendices	38
A - Remote Run/Hold Kit Installation	39
B - Magnetic Speed Sensor Installation	40
C - Fine Tuning Speed/Distance Calibration Value	43
D - Fine Tuning Flowmeter Calibration Value	44
E - "Quick Start" Function	45
F - NH3 Control	46
G - "Open Loop" Control & Closed Loop Override	58
H - Pulse Width Modulation (PWM) Live Calibrate	59
I - Pressure Based Control	63
J - Default Calibration Values	64
K - Radar Adapter Cables	65
L - Conversion Chart	66
M - Replacement Parts List	67
N - Electric Motor Driver - Setup & Connectivity	68

Component Parts and Hardware



SprayMate™ Plus Console
P/N 18700

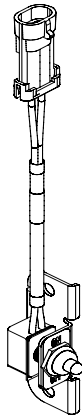

Power Switch Kit
P/N 21779

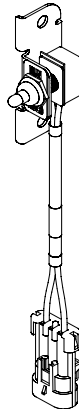

Run/Hold Switch Kit
P/N 21778



Reference Manual
P/N 18770

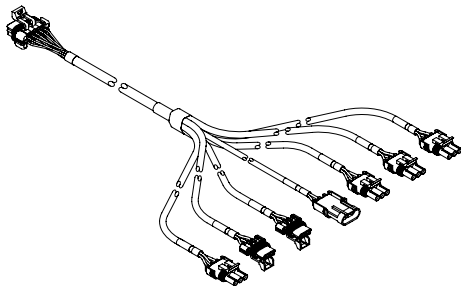

Branch Harness
w/Weather Pack Tower Conn.
P/N 18532

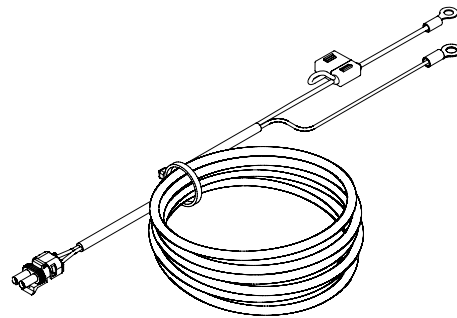

Power Cable
P/N 14315

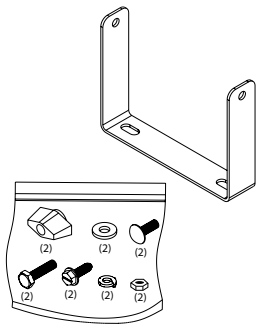

Console Mount Kit
P/N 13181

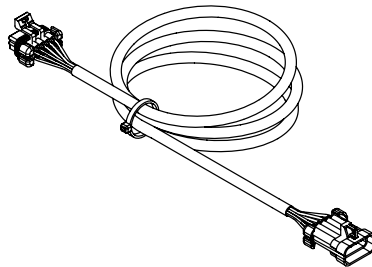

120" 10-pin Extension Cable
P/N 14316

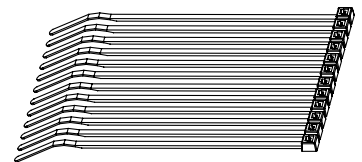

14" Nylon cable ties (10)
P/N 12910

System Overview

Note: Branch Harness diagram shown is P/N 18532 w/Weather Pack **Tower** connectors. The P/N 18280 cable w/ Weather Pack **Shroud** connectors has the same layout.

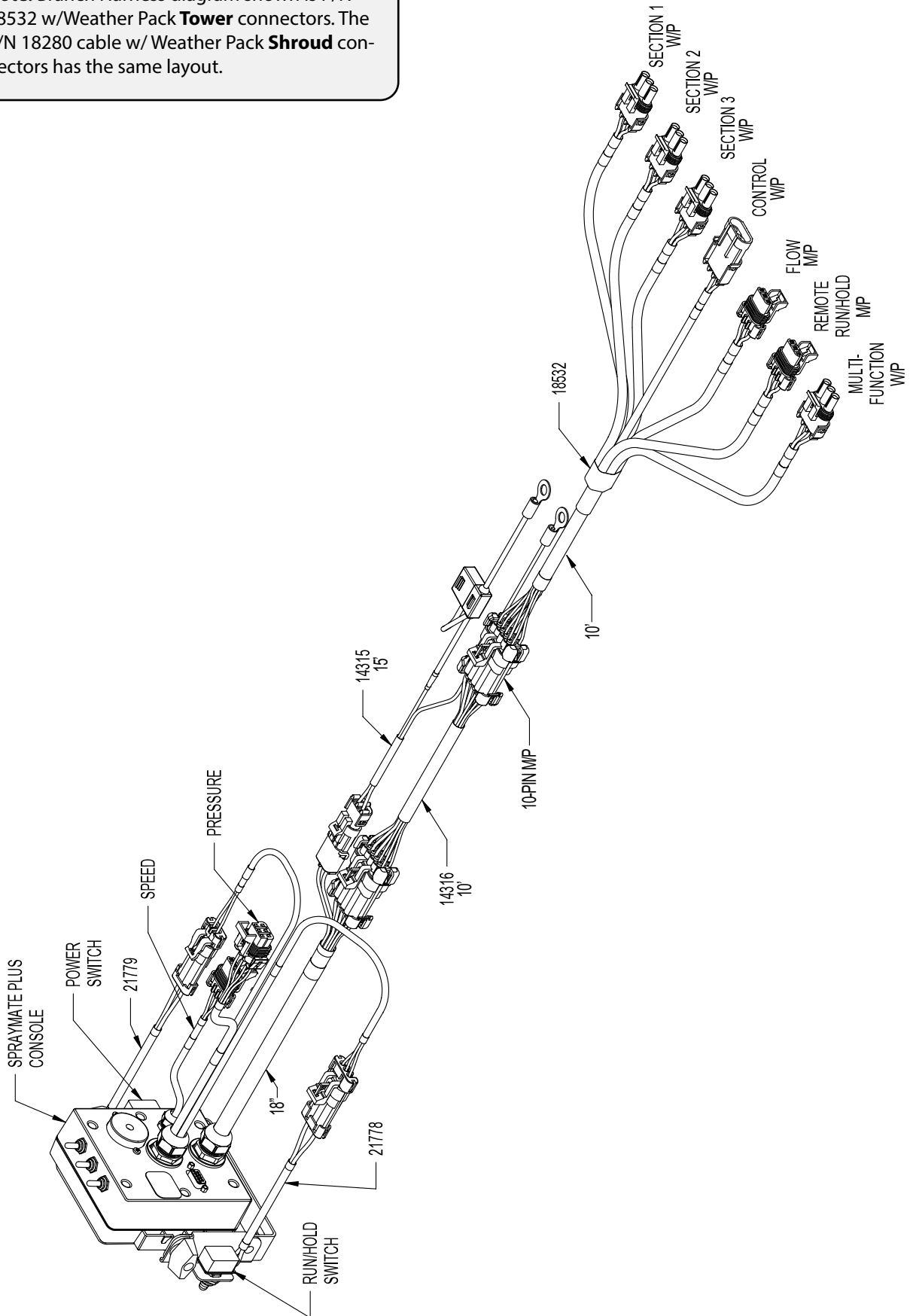

Wiring Diagram

Note: Branch Harness shown is P/N 18532 w/Weather Pack **Tower** connectors. The P/N 18280 cable w/ Weather Pack **Shroud** connectors has the same wiring layout.

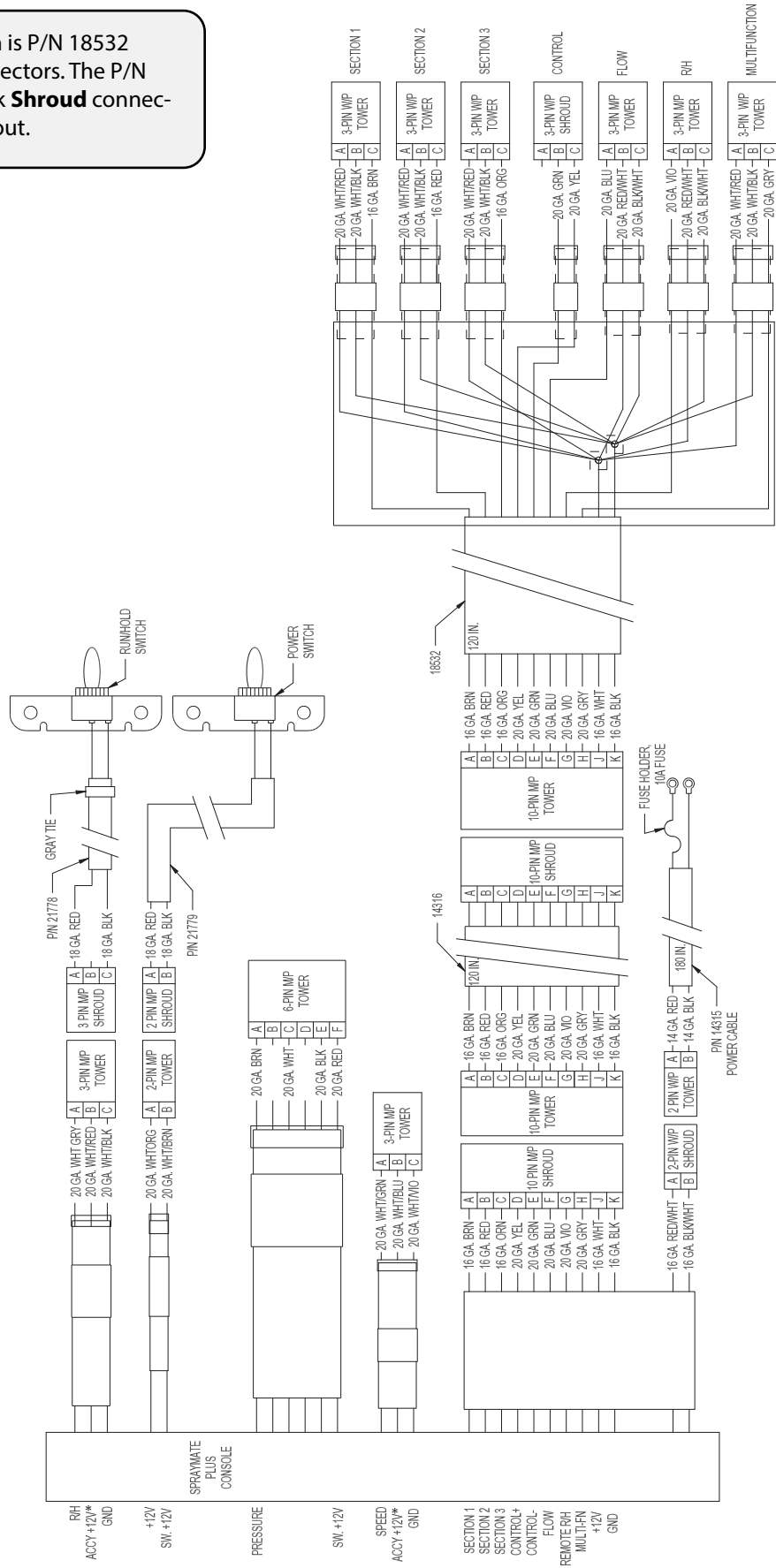

Installation

Overview

Install the SprayMate™Plus console and system components by following the recommended sequence of steps. Your installation may not include some of these steps; some equipment is optional and some components may already be installed. **All** installations **must** follow Calibration and Pre-Field System Checkout steps (9,10) to ensure safe and accurate operation of system.

Installation Steps

1. Mount the Console, Power Switch, and Run/Hold Switch.
See page 9.
2. Route wiring to appropriate locations on vehicle and/or implements.
See page 10.
3. Connect wiring harness to 12VDC power.
See page 10.
4. Connect wiring harness to Section Shutoff valves.
See page 10.
5. Mount Speed Sensor and connect to system.
See page 12.
6. (Optional) Mount Implement Switch and connect to system.
See page 13.
7. Mount Flowmeter and join to system.
See page 16.
8. (Optional) Mount Pressure Sensor and connect to system.
See page 16.
9. Calibrate SprayMate™ Plus system.
See page 21.
10. Perform Pre-Field System Checkout Procedure.
See page 32.

Installation (cont.) Mounting the Console

Select a mounting location which seems most workable, and best fits your needs. It should be convenient to reach and highly visible to the operator. **DO NOT INSTALL IN A POSITION THAT OBSTRUCTS THE VIEW OF THE ROAD OR WORK AREA.** Whenever possible, avoid locations that expose the console to direct sunlight, high temperature, strong chemicals or rain.

Place the mounting bracket in the selected location, mark holes, drill $\frac{1}{4}$ " (7mm) holes and mount bracket with bolts, lock washers and nuts provided. (Use self-tapping screws if not practical to use bolts.)

See Figure 1.

Put rubber washers on carriage bolts and put the bolts through the bracket holes from the inside out. Slide console over carriage bolt heads.

Install the switch brackets over the carriage bolts and alongside the console bracket. Install the mount knobs on the carriage bolts and tighten to secure the console and switch brackets in place. **See Figure 2.**

Mount the switches in the brackets then join the switch harness connectors to the mating connectors on the console harness. Typically the power On/Off switch (Kit 21779) is mounted on the left and the Run/Hold switch (Kit 21778) is mounted on the right. **See Figure 3.**

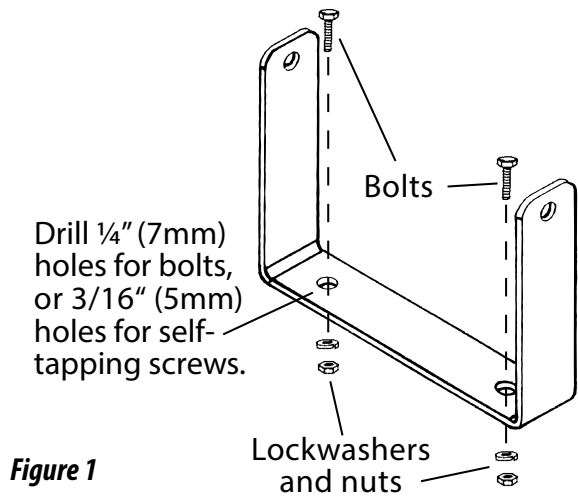

Figure 1

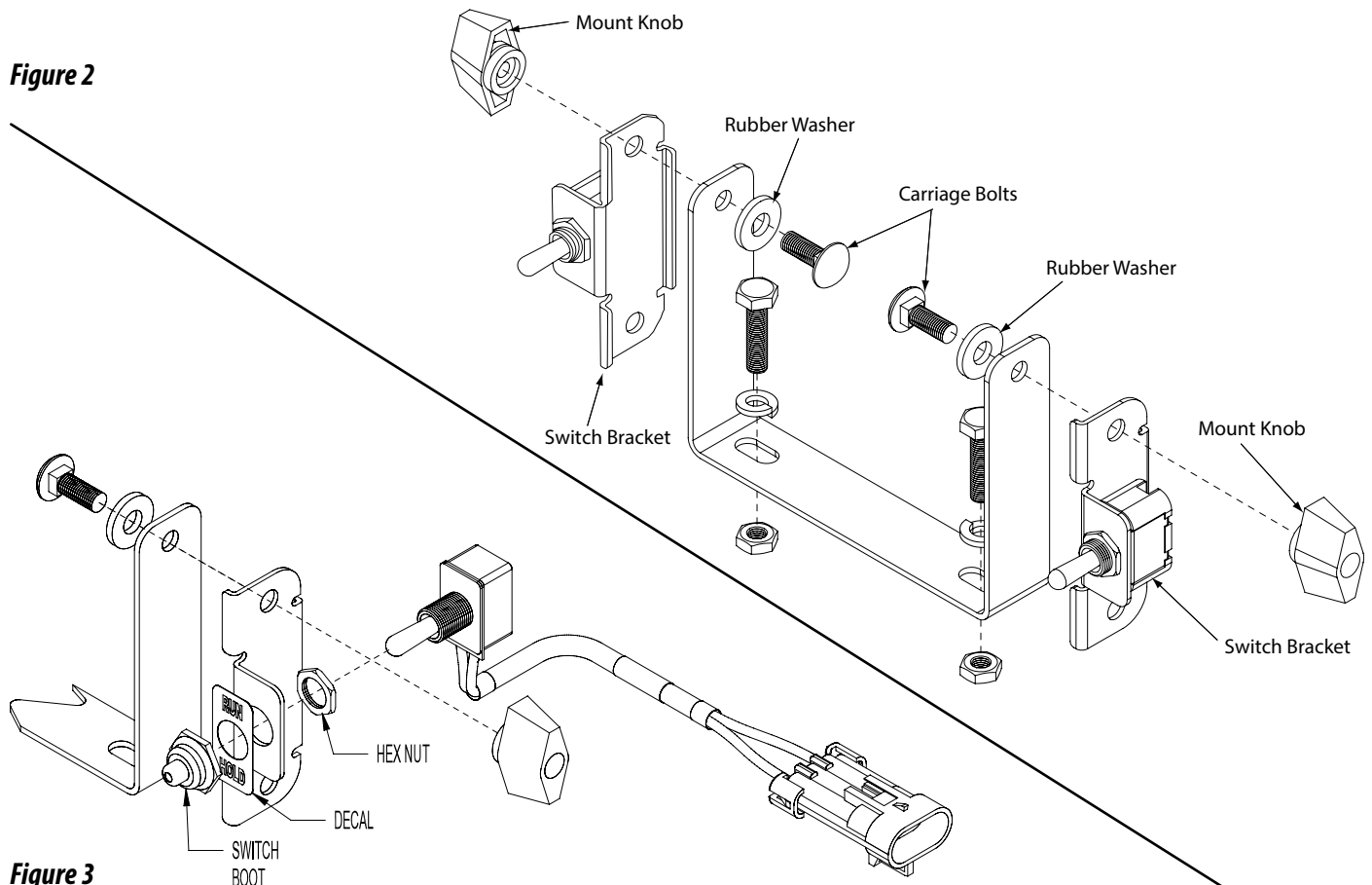

Figure 3

Installation (cont.)

Electrical Installation

This section explains how to hook-up your SprayMate™ Plus to a 12VDC power connection and On/Off Switch, and wiring information about section shut-off valves connections.

The SprayMate™ Plus must be connected to a 12VDC negative ground electrical system.

ROUTING HARNESS AND CABLING

Avoid areas where the cable may be subjected to abrasion or excessive heat.

WIRING HARNESS ORIENTATION

Wiring with multiple branches must be installed so that the individual wires point downward, as shown. This will protect the internal connections from exposure to liquid chemicals.

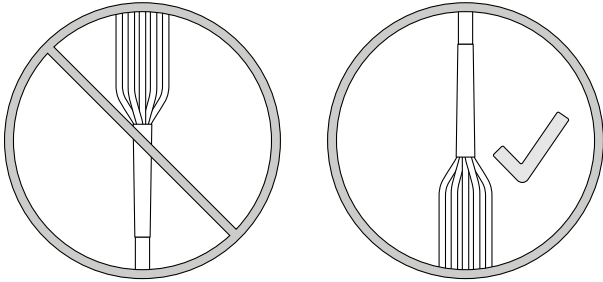

POWER/BATTERY CONNECTION

Locate the power cable lead on the SprayMate™ Plus harness and route to the battery. Attach the BLUE wire to ground. **See Figure 4.** Be sure there is a good metal-to-metal contact. Connect the ORANGE wire to the positive battery terminal.

Connect the power to the SprayMate™ Plus console by plugging the 2-pin W/P tower on the power cable into the 2-pin W/P shroud connected to the display console.

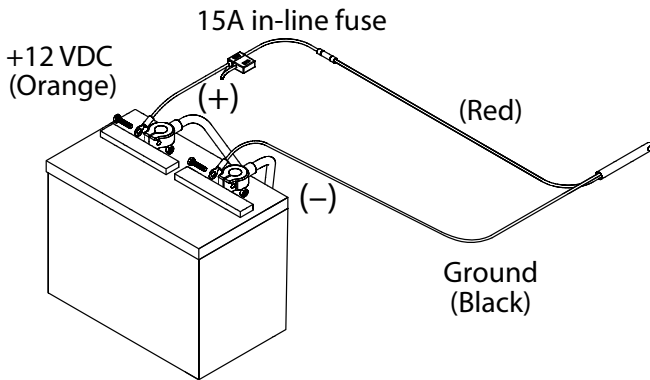

Figure 4 - Power/Battery Connection

SECTION SHUT-OFF VALVES

The SprayMate™ Plus branch harness includes connections for 3 section valves. The wiring to each Weather Pack connector consists of +12VDC, Ground, and switched +12VDC. **See Figure 5.** For solenoid type valves, use connections **B** and **C** only.

Verify the wiring layout of your valves **before** connecting them to the SprayMate™ Plus. Please refer to original valve documentation or contact valve manufacturer if you are unsure of the correct wiring configuration.

WHT/RED	A	3-Pin Weather Pack Tower/Shroud Connector	Constant +12VDC
WHT/BLK	B		Ground
Color of wire varies by section	C		Switched +12VDC (Signal)

Figure 5 - Example Section Valve Connection

Installation (cont.) Branch Harness Connections

Note: Branch Harness shown is P/N 18532 w/Weather Pack **Tower** connectors. The P/N 18280 cable w/ Weather Pack **Shroud** connectors has the same wiring layout.

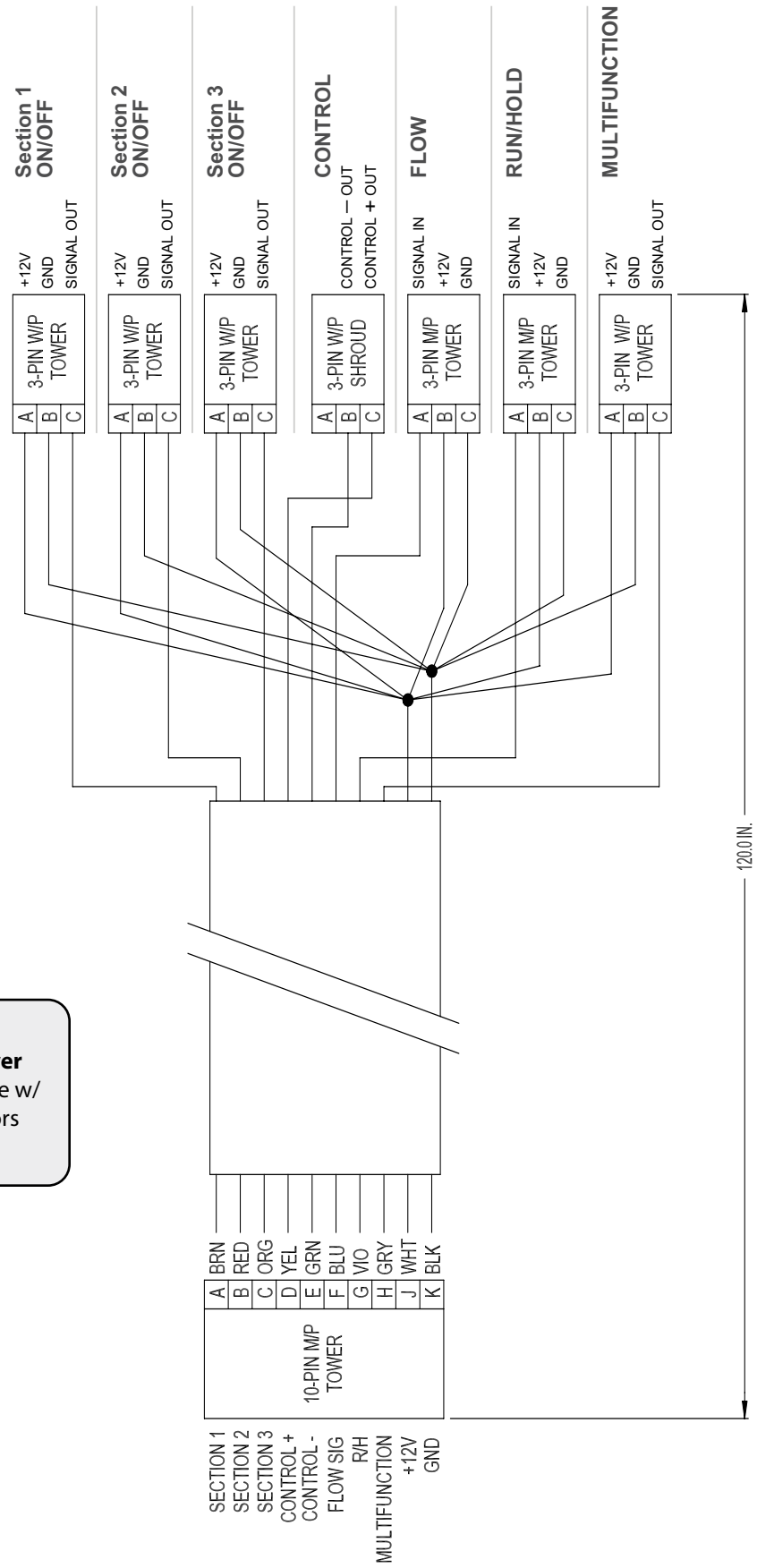

Installation (cont.)

Speed Sensor Options

The SprayMate™ Plus must be connected to a speed sensor to utilize its calculating function. Several possible options are listed below:

ASTRO SERIES OR OTHER GPS SPEED SENSOR INTERFACES

The SprayMate Plus is designed to easily connect to the Micro-Trak Astro series speed sensor. It also may be used with most GPS speed sensors that output a pulsed signal, such as the Squibb-Taylor® SkyTrak or Dickey-John® GPS speed sensors. An adapter cable may be required.

MAGNETIC WHEEL SENSOR

This system uses magnets attached to a wheel hub or drive shaft and a hall-effect sensor. The movement of the magnets near the sensor creates an electrical pulse which the console uses as a speed input. The system must be carefully calibrated to ensure accurate readings. **SEE APPENDIX B FOR MAGNETIC SENSOR INSTALLATION.**

VANSCO™ RADAR SPEED SENSOR (AVAILABLE FROM MICRO-TRAK DEALERS & DISTRIBUTORS)

The Vansco radar speed sensor uses a microwave (radar) signal to deliver a reliable, accurate speed signal for electronic equipment. It features state-of-the-art electronic design/manufacturing, rugged aluminum housing and complete testing and certification.

RADAR INTERFACE

The SprayMate™ Plus may also be interfaced with most popular radar ground speed sensors. An adapter cable is required for proper interface.

SEE Appendix K FOR LIST OF ADAPTER CABLES FOR RADAR.

ASTRO SERIES GPS SPEED SENSOR INSTALLATION:

RECEIVER: The GPS receiver may be mounted either externally (roof of the cab or other place with a clear view of the sky) or inside the vehicle cab. However, if mounted inside the cab there may be some loss of accuracy due to blockage of satellite signals. For most reliable operation, mount the GPS receiver in a location where it has an unobstructed view of the sky. Mount the receiver using the integral magnet or the included self-adhesive fastener tape. If using the fastener tape - clean the mounting location, remove the plastic backing, and press firmly to the surface.



WIRING: Route the 10 foot cable from the receiver into the cab (if receiver is externally mounted). Avoid sharp edges or heat sources. The rectangular module is roughly the same size as the connector and will fit through the same opening.

MODULE: The small potted module includes a power LED and a GPS status LED. The module can be mounted in a visible location using the included self-adhesive fastener tape, or placed out of sight.

- **Power LED** (closest to connector) : On when 12VDC is connected
- **GPS Status LED** (closest to receiver): Flashes when the GPS receiver is active and scanning for a satellite. When a signal is found, it will remain on. If the GPS system fails, the light will turn off.

CONSOLE CONNECTION: Connect the short cable from the Astro to the 3-pin connector labeled SPEED on your console.

Proximity Sensor

Micro-Trak® also offers a proximity sensor - P/N 01554 Gear tooth sensor kit. It is useful in situations where it is impractical or inadvisable to use a flowmeter to monitor flow of material. It can also serve as a Speed sensor. The 01554 Gear tooth sensor responds to the close presence of ferrous metals and sends a signal to the console via the Flow or Speed connection. The recommended air gap between sensor and moving part is 1/16" (tip: use a U.S. dime as a gauge). To calibrate the system to use this sensor for Flow, use the Appendix D - Fine Tuning Flowmeter Calibration, for Speed, use Appendix C - Fine Tuning Speed/Distance. For use as a Flow monitor for PWM systems, use Appendix G - Closed Loop Live Calibration for PWM control.

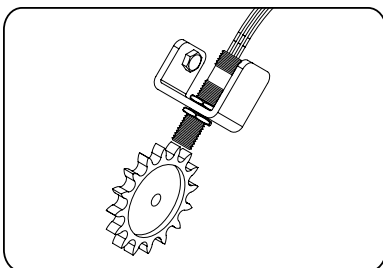

Installation (cont.)

Optional Equipment - Switches

Micro-Trak offers two options for automatically controlling the operation of the SprayMate Plus system. Both solutions mount directly to your implement and control run/hold as the machine is operated. Installation locations vary by the type of machinery used. Both types of Implement Switch join to the "Run/Hold" connection on the Branch Harness.

Whisker Switch Assy. - P/N 18541

Simply mount the Whisker Switch Assembly near a moving part of an operating mechanism on your implement (additional extension cables may be needed). The connector labelled "SafeGuard Run/Hold" is wired Normally Open. The default polarity for the SprayMate Plus Run/Hold circuit is preset to "Closed", meaning pressure on the switch tip causes the system to "Hold". See figure 6. The polarity setting can be accessed in Special Calibration settings (see page 23) - it is called "Hold Input Polarity".

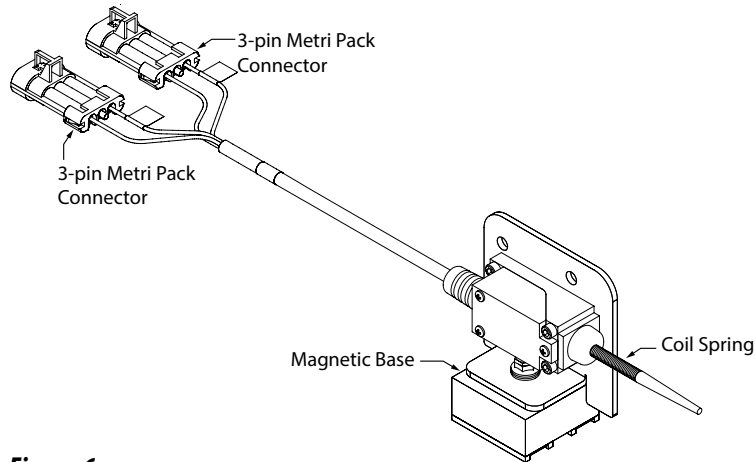

Figure 6

Remote Run/Hold Sensor Kit- P/N 01535

The Remote Run/Hold Sensor consists of a Hall-effect proximity sensor and a magnet. Mount the sensor near a moving part of an operating mechanism on your implement; mount the magnet on the moving part (additional extension cables may be needed). The sensor is wired Normally Open; the default polarity for the SprayMate Plus Run/Hold circuit is preset to "Run". Moving the magnet close to the sensor tip causes the system to "Hold". See figure 7. The polarity setting can be accessed in Special Calibration settings (see page 25) - it is called "Hold Input Polarity". More extensive instructions on installing the Remote Run/Hold Sensor can be found in Appendix A.

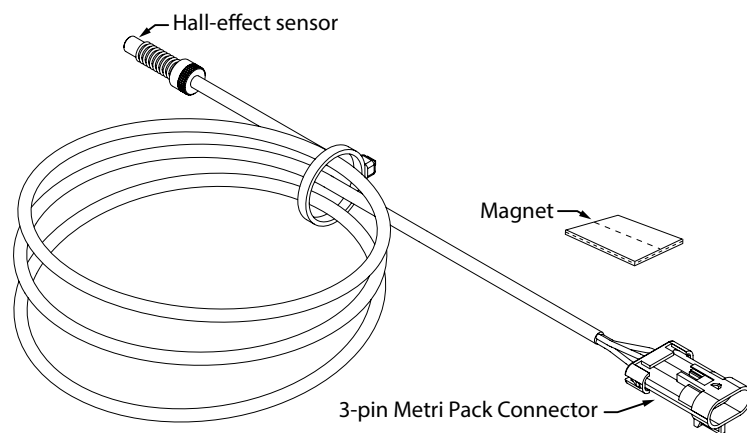

Figure 7

Contact a Micro-Trak® dealer or distributor for more information on these accessories.
A Dealer Locator can be found online at <http://www.micro-trak.com/where-to-buy/dealer-locator>.

Installation (cont.)

SprayMate™ Plus Plumbing Overview

Bypass Configuration - Flow through servo bypasses flowmeter

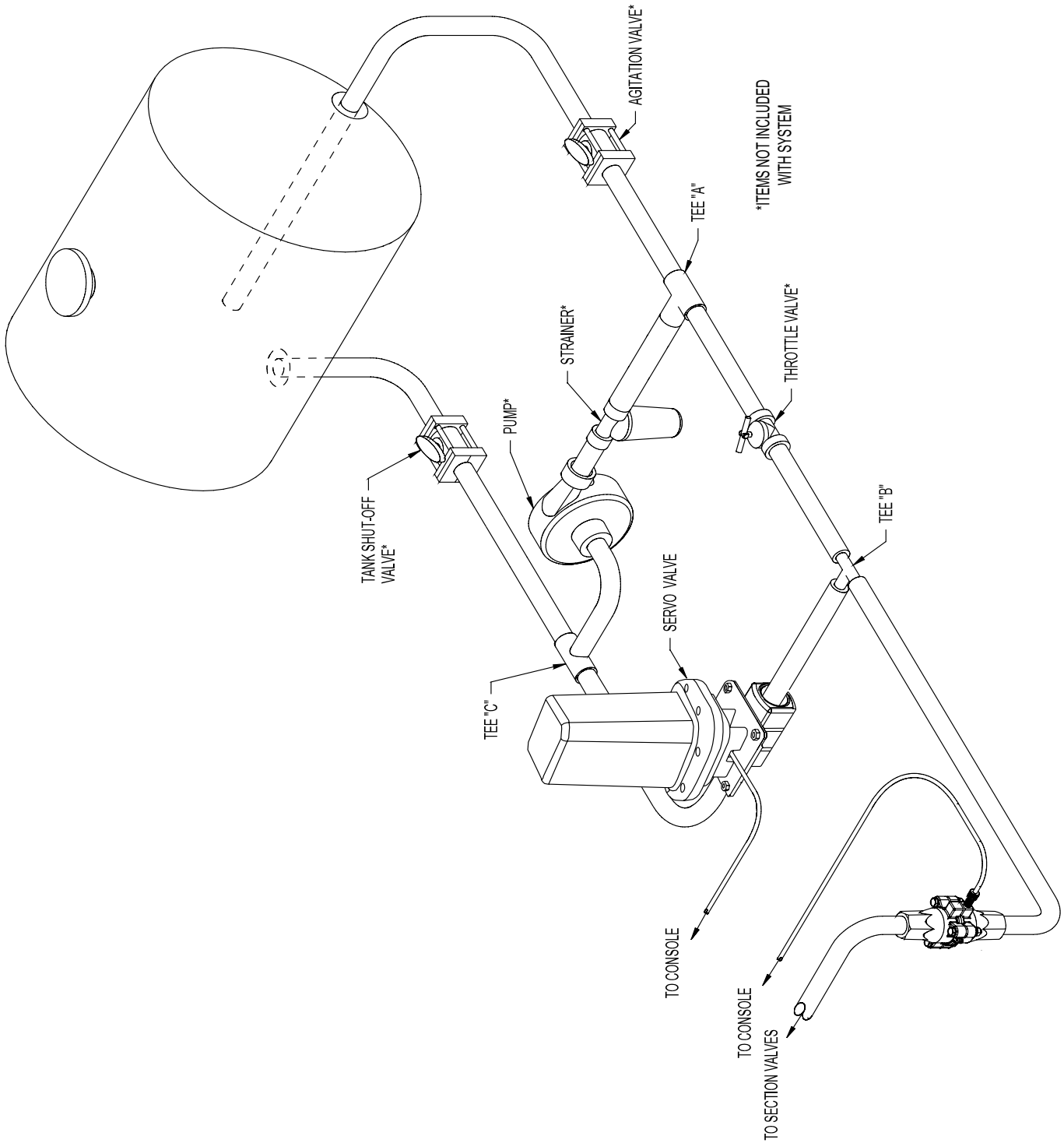

Installation (cont.)

SprayMate™ Plus Plumbing Overview

In-Line Configuration - Flow through servo is inline with flowmeter

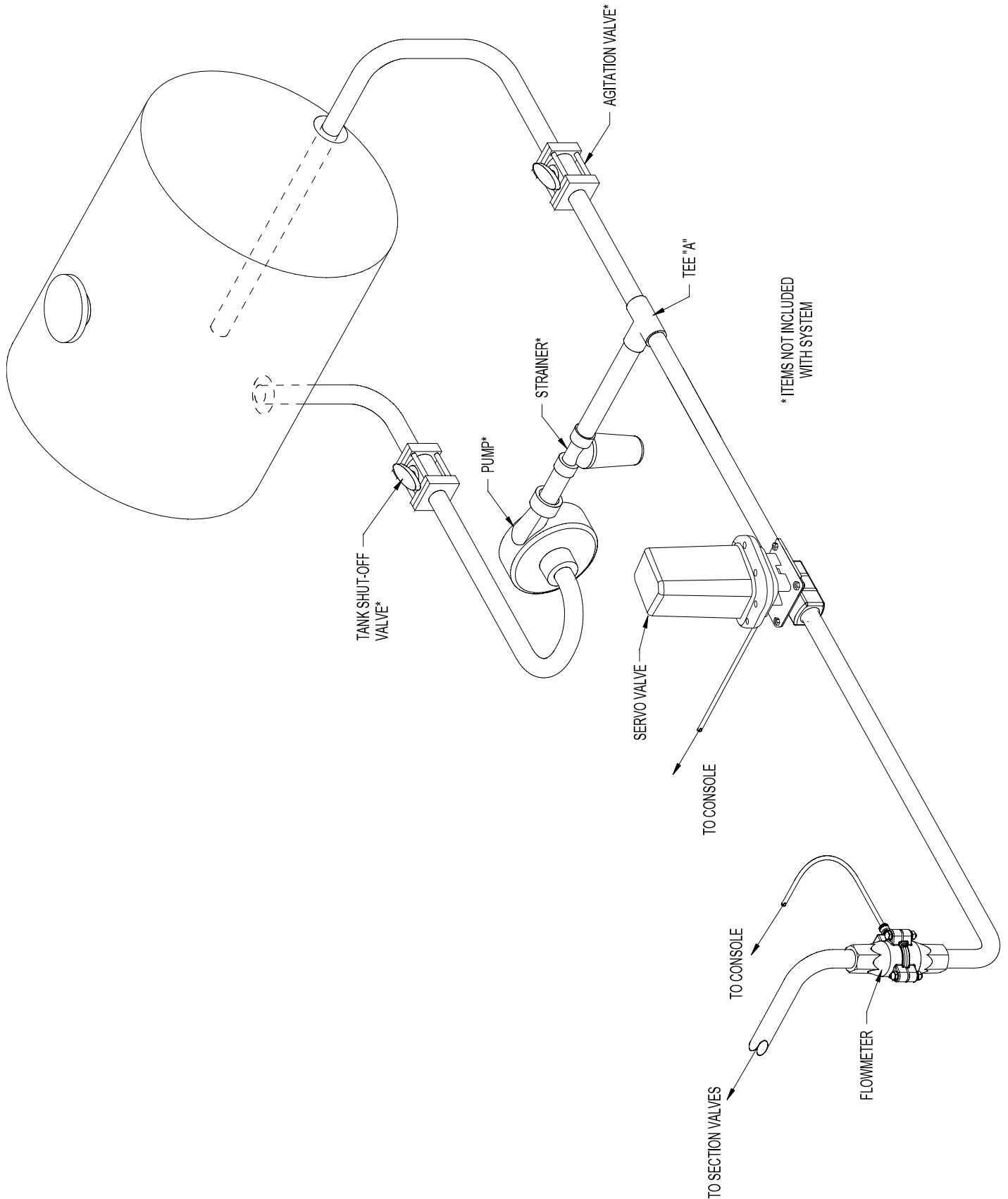

Installation (cont.)

System Components

Installing Flowmeter

The flowmeter must be installed in the main line after any strainers, return lines, or valves. Securely mount flowmeter in an area away from intense vibration. A vertical installation with flow entering the bottom is preferred, especially at rates below 5 gallons per minute. **See figure 8.** Other orientations are sufficient providing the flowmeter remains full of fluid. To avoid erratic flow readings allow a minimum of 6" of straight tubing at the flowmeter input and output. If installation constraints don't allow this keep bends as gentle as possible. Micro-Trak® flow meters are bidirectional (exception: green plastic turbine and mag flowmeters are one direction only). Flipping the flowmeter periodically (black nylon and stainless steel Micro-Trak® manufactured models) to reverse the flow will greatly extend the life of the flowmeter by evening out bearing wear.

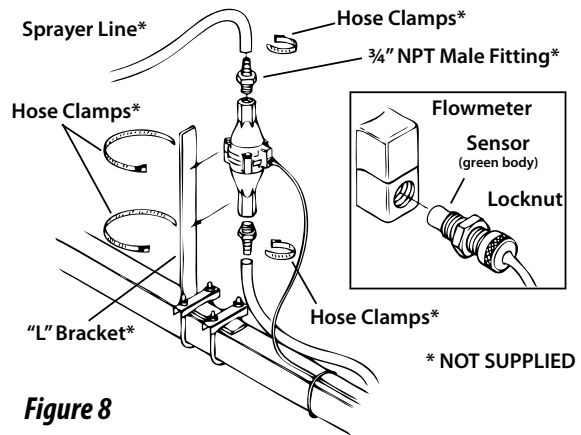

Care and Maintenance

At end of application season, thoroughly flush Flowmeter with clean water, and drain completely.

- The input pressure on the glass-filled nylon flowmeter FM750 GFN should not exceed 100 PSI (689 kpa).
- Do not expose the flowmeter to liquid temperatures exceeding 130 degrees F (55 degrees C).
- Some chemicals may damage the turbine material - Noryl GTX. If you are in doubt, contact the chemical manufacturer.

Installing Flow Sensor Cable

The flow sensor cable has a GREEN sensor body and joins the 3-pin connector on the wiring harness marked FLOW. **See figures 9 and 10.**

1. Screw threaded sensor into hole of flowmeter until seated.
2. Gently tighten 3/8" jam nut to secure sensor in place.
3. Uncoil flow sensor cable and route it to wiring harness.
4. Align connectors and press firmly together until locking tab clicks into place.
5. Secure cable with plastic ties provided.

See SprayMate™ Plus Wiring Diagram on page 7.

NOTE: Sensors with GREEN bodies can be used for either SPEED or FLOW but not for REMOTE RUN/HOLD.

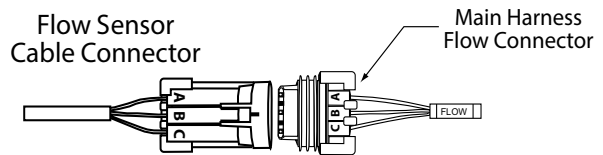
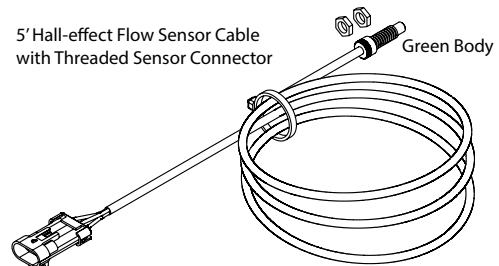

Installing Pressure Sensor (Optional)

The pressure sensor should be installed in the main line of flow as close to the section shut-off valves as possible. The sensor requires a 1/4" - 18 NPT fitting. **See figure 11.**

1. Install the sensor in the plumbing line.
2. Join the cable to the 3-pin Packard™ connector on the sensor.
3. Route the cable (and extension cables, if needed) to the console location - avoid sharp surfaces and heat sources.
4. Join the cable to the **PRESSURE** connection on the wiring harness - align connectors and press firmly together until locking tab clicks into place.

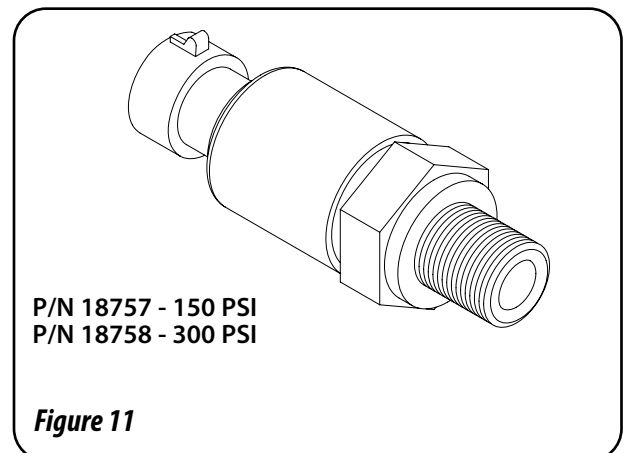

Installation (cont.) System Components

Bypass Valve

With oversized pumps, it may be necessary to install a bypass valve. This valve allows excess flow to return to the tank. This in turn reduces the pump output to the rest of the system. *See Figure 12. Adjustment of this valve is covered in the Pre-Field System Checkout, page 32.*

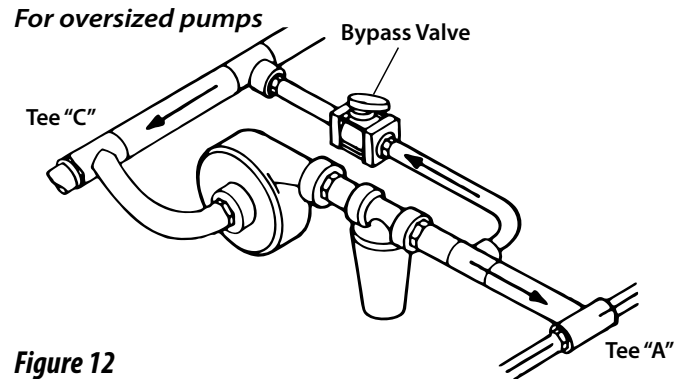

Figure 12

Manual Pressure Relief Valve

If you have a positive displacement pump or a centrifugal pump capable of generating excessive pressure, you must install a pressure relief valve and adjust it to a safe maximum pressure. If a positive displacement pump is operated without a pressure relief valve, pump or other plumbing components may be damaged. *See Figure 13.*

For positive displacement pumps

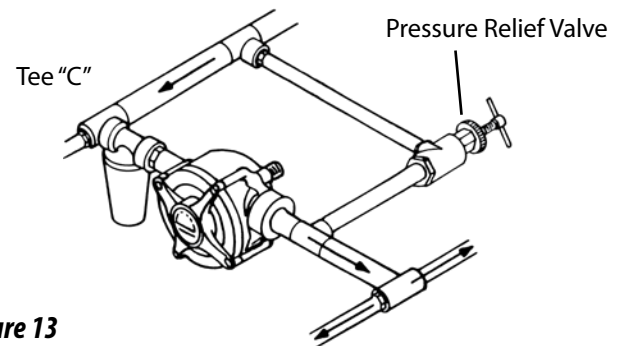

Figure 13

Servo, Throttling Valves

For BYPASS installations, the servo valve installs in an unrestricted return line to the inlet of the pump or directly into the tank. The console must be calibrated for bypass operation, *see Calibration section. DO NOT install the servo valve closer than 12" to the flowmeter.* The servo valve has a flow direction decal on it. Make certain that the actual flow direction matches the decal on the servo valve. **DO NOT** install the servo valve in the agitation line. Slow response time and marginal operation may result. The return line should tee from the main line just after the throttling valve. *See Figure 14.* The throttling valve is used to limit the output (set maximum output) of the pump to the flowmeter and servo valve. The throttling valve is adjusted to put the servo valve in its optimal operating range. *Please refer to Pre-Field System Checkout on page 32 for proper valve adjustment procedure.*

The servo valve connects directly to the 3-pin connector on the main harness. If more length is required, use a 3-pin W/P extension cable of the appropriate length.

NOTE: For Inline operation, the servo valve is installed in the main spray line as shown in Figure 15.

Bypass

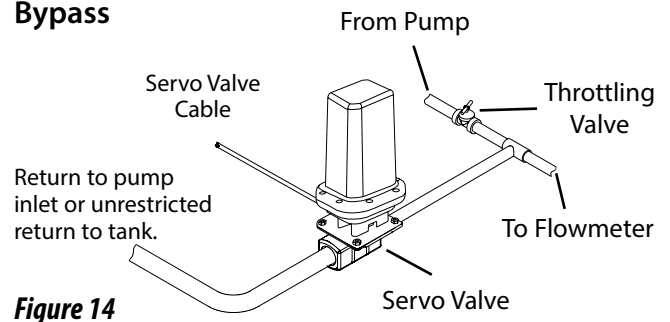

Figure 14

Inline

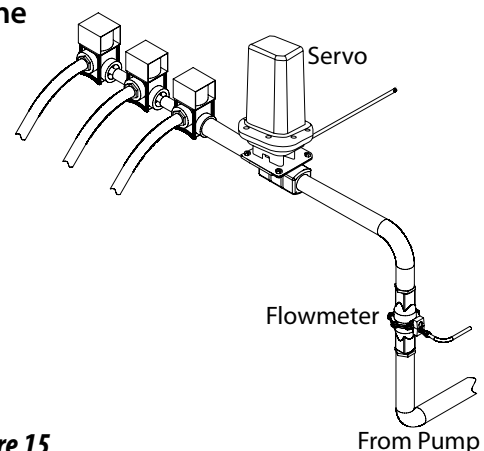

Figure 15

Feature Summary

Basic Features

- Operates in LIQUID or NH₃ application modes in Metric, English or Turf units:
 - **English:** Area units are acres, distance is feet, flow is gallons or lbs-NH₃ per minute and application rates are in gallons or lbs-N per acre.
 - **Metric:** Area is measured in hectares, distance is in meters, flow is liters or kg-NH₃ per minute and application rates are in liters or kg-N per hectare.
 - **Turf,** where the area units are in 1000 Square Feet, distance is in feet, flow is gallons or lbs-NH₃ per minute and application rates are in gallons or lbs-N per 1000 Ft².
- The following can be selected for display: Volume, Area (each have 3 independent counters), Distance, Pressure, Speed, Application Rate, Tank Level, Volume/Minute.
- SprayMate™ Plus can operate with 1 to 3 Sections with individually adjustable widths. Three section switches are located on top of the Console or external section switches can be used.
- Flow Input can be calibrated to allow use of a variety of meters or encoders for feedback
- Speed Input can be calibrated to allow use of a variety of speed sensors.
- Tank size can be entered for quick reset of the Tank Level. A Tank level can be set to generate an alarm (LED, message and audible) when the calculated tank level is less than the set point.
- Warning messages for No Speed and No Flow while in Automatic control and Application Rate position.
- When off Target while under auto control an adjustable 'Rate Alarm Threshold' will determine when a warning is given (audible and red Warn LED flashes).

Rate Control

- Automatic control maintains a set Target Application Rate, and Manual control (can be disabled in "Special" calibration) allows the operator to manually control the Application rate.
- When in the RATE position and in automatic control, the Target Application Rate can be increased or decreased (**Increase/Decrease** buttons) by a selectable Adjust Rate.
- A Control Response setting (Control Speed) allows the control valve speed to be optimized for the system and the servo control can be set for Bypass or Inline configurations (Valve Polarity).
- A Minimum Flow (Gallons or Liters per minute) feature controls minimum flow to system. Useful for maintaining nozzle spray pattern - use nozzle manufacturer's charts to calculate minimum flow value.
- 'Auto Delay Time' can be set from 0 to 4 seconds to delay Automatic control when starting application, This allows time for shut-off valves to completely open and flow to stabilize before attempting control.
- When in Manual control and in either the VOLUME/MINUTE or RATE positions, the Application Rate can be increased or decreased using the **Increase/Decrease** buttons.
- When in Automatic control and in the VOLUME/MINUTE position and in Hold, the Flow Rate can be increased or decreased using the **Increase/Decrease** buttons (Standard DC drive only).
- When in Automatic control, if no flow signal is detected for a period of time, the Emergency Stop feature will stop flow (close the control valve) and display the "noFl o" warning message.
- 'Auto Shut Off' can be enabled to use the Standard DC control valve to stop flow (close control valve) when in Hold, no sections are on, or no ground speed in Automatic control.

Feature Summary (cont.)

- Supervisor Lockout Mode - activated in Special Calibration mode. When locked, it allows operator to view calibration numbers but prevents changes. It also allows only Data Set 1 to be cleared (volume, area and distance) but prevents clearing Data Sets 2 and 3.
- Can be set to work with either Standard or FTW (Flow Three Way) Section valves.
- Selectable servo drive options, Standard DC servo and Pulse Width Modulation (PWM) with adjustable PWM frequency and PWM maximum/minimum limits.
- Multi-Function Output with selectable functions:
 - **Always OFF:** Output is unused.
 - **Always ON:** Output high whenever the console is powered on.
 - **Relief Valve:** Output high when in Hold or all sections off.
 - **Master:** Output high when in Run and at least 1 section on.
 - **Flush:** Output high for settable time after a Run to Hold transition and a settable pause interval. Audible indicator of the Flush cycle completion.
 - **F-FLO (Fixed Flow Trigger)** - On when the Flow per Minute reaches a User-settable fixed total flow rate.
 - **P-FLO (Proportional Flow Trigger)** - On when the Flow per Minute reaches a User-settable flow rate, proportional to active sections.
- Open Loop and Closed Loop Override control (PWM drive)
- A "Quick Start" feature can be enabled for triggering immediate application when in Automatic operation. Two different methods are available:
 - Quick Start - SPEED** provides an instant simulated speed whenever the system goes from HOLD to RUN. This triggers instant application using **Start Speed** and **Start Speed Time** - Special Calibration parameters.
 - Quick Start - VALVE** provides a "jump start" to open the control valve by running it immediately after some movement is detected. This triggers instant application using **Start Time (STD)** or **Start Percentage (PWM)** - Special Calibration parameters.
- 'Application ID' setting - assigns a unique ID number to the data to identify specific jobs or vehicles
- Audible alarm output (can be disabled) for notification of Rate errors over 'Rate Alarm Threshold' or Tank level below set point, or Pressure above or below Hi or Low alarm level.
- Optional Pressure Sensor to monitor system pressure. SprayMate Plus can also be configured for pressure based flow control.
- Fixed Minimum Flow feature sets an absolute minimum value for flow. This ensures that the flow rate is never less than the lowest range of the flowmeter - preventing the flowmeter from stalling.

Serial Port

- Selectable VRA Serial Protocol (Micro-Trak® or Raven®) to interface with GPS/Mapping Controllers for Variable Rate Application (VRA) including Target Hold.
- User can override the GPS/Mapping Controller to apply a rate above or below the prescription rate or override Target Hold.
- Serial commands to support AVL (Automatic Vehicle Location) data collection methods: Totals data list includes the Application ID, and all data sets. Equipment data list includes Controller Type, Application ID, section widths, measurement units and application mode.

SprayMate™ Plus Console Function Summary

The SprayMate™ Plus features a large, easy-to-read liquid crystal display, easy-to-use rotary dial and lighted panel for night use. The console also includes section switches, an audible alarm, and a serial port.

VOLUME (1) (2) (3): Displays the total volume of product applied in gallons (liters) or lbs (kg) of NH₃. May be reset. **SEE NOTE**

VOLUME/MINUTE: Displays total gallons (liters) of liquid applied per minute, or lbs. (kg) NH₃ per minute.

TANK: Displays gallons (liters) of liquid remaining or lbs. (kg) of NH₃ remaining.

RATE: Displays application rate in the following units of measurement based on the UNITS and MATERIAL settings.

	Liquid	NH ₃
English	Gallons/Acre	lbs-N/acre
Metric	liters/hectare	kg-N/hectare
Turf	Gallons/1000 Ft ²	lbs-N/ 1000 Ft ²

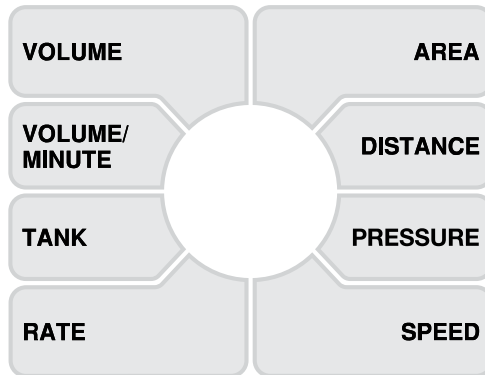

AREA (1) (2) (3): Keeps a running count of the total area worked in acres (hectares) or 1000 Ft² in Turf Units May be reset. **SEE NOTE**

DISTANCE: Displays Distance traveled in either Feet or Meters. May be reset.

PRESSURE: Displays system pressure (if pressure sensor is connected to system).

SPEED: Displays ground speed in miles per hour (kilometers per hour).

WARNING LIGHT: Flashes to indicate over or under application of +/- *10% from the Target Rate, a low tank level, too high or too low Pressure reading, or that Minimum Flow feature is active. Also lit when in CAL and Unlocked.

*NOTE: % adjustable via 'Rate Alarm Threshold'.

NOTE: VOLUME and AREA counters function in pairs. If the VOLUME counter 1 is reset, it also resets AREA counter 1. There are 3 independent data sets. The number icon indicates which counter set is shown. If console is in Supervisor Lockout then only Data Set 1 can be cleared. Counters do not accumulate data when console is in HOLD or sections are turned off.

Left Side Calibration Positions

FLOW CAL: Enter the calibration value assigned to your flowmeter (*see flowmeter tag.*) Set to 0 to enable Pressure Based Control.

MIN FLOW: Optional setting - can be left at 0 (Off). Used to enter a desired minimum flow rate, gallons/min. (liters/min.) to maintain nozzle spray pattern.

ADJUST RATE: Enter an amount of change for on-the-go adjustments to the target rate.

TARGET RATE: Enter the target application rate.

NOTE: If console is locked (by using Supervisor Lockout), the calibration factors can be viewed but not changed.

Right Side Calibration Positions

WIDTH CAL: Enter the working width of the sprayer boom (or other equipment). Press CAL button to select individual sections.

SPEED CAL: Enter the speed calibration number in inches (cm) per pulse.

CONTROL SPEED: (Optional) Used to adjust the response time (speed) of the control valve for a particular system.

TEST SPEED: (Optional) Can be used as a test mode to simulate ground speed for system checkout. Enter a Test Speed in miles per hour (kilometers per hour).

Button Functions



Changes operation from automatic control to manual. (If Manual Control is enabled).



- Used to enter & exit the calibration mode.
- Used to select the Section # in 'Width Cal' position.
- Used to select the page # in "Special" Calibration.
- Toggles between SPEED CAL and Distance traveled while fine tuning the SPEED CAL factor or between FLOW CAL and Volume when fine tuning the Flow Cal factor. *See Appendices B & C.*



INCREASE/DECREASE

- In normal operating modes, used to increase/decrease application rate.
- In Volume, Area, or Distance, the "+" button selects the counter set.
- RESET: When in Hold and not in CAL, clears the selected counter set when held for one second.
- When in CAL, the "+" button increases and the "-" button decreases the calibration value displayed.

Calibration

Before operating the SprayMate™ Plus, it is necessary to calibrate it for the intended operation. The first step is choosing intended UNITS (English, Metric, or Turf) in Special Calibration, page 23 - this will also load default values. We recommend to complete all Special Calibration adjustments before returning to Calibration setup.

CALIBRATION STEPS:

1. Stop the vehicle, if moving.
2. Switch console to HOLD, or turn all section switches OFF.
3. Press and hold the CAL button about 1 second until the 'CAL' icon appears on screen and Red LED light is on.
4. Select calibration position on rotary selector (see explanations of each position starting on page 22).
5. Adjust values using Increase/Decrease buttons.
6. To exit Calibration without saving changes - turn console OFF.
7. To save changes and exit Calibration - press and hold the CAL button for 1 second - 'CAL' icon on screen will turn off and red LED light will turn off.

NOTE: If console is locked, Calibration values can be viewed but not adjusted. Test Speed position is always active.

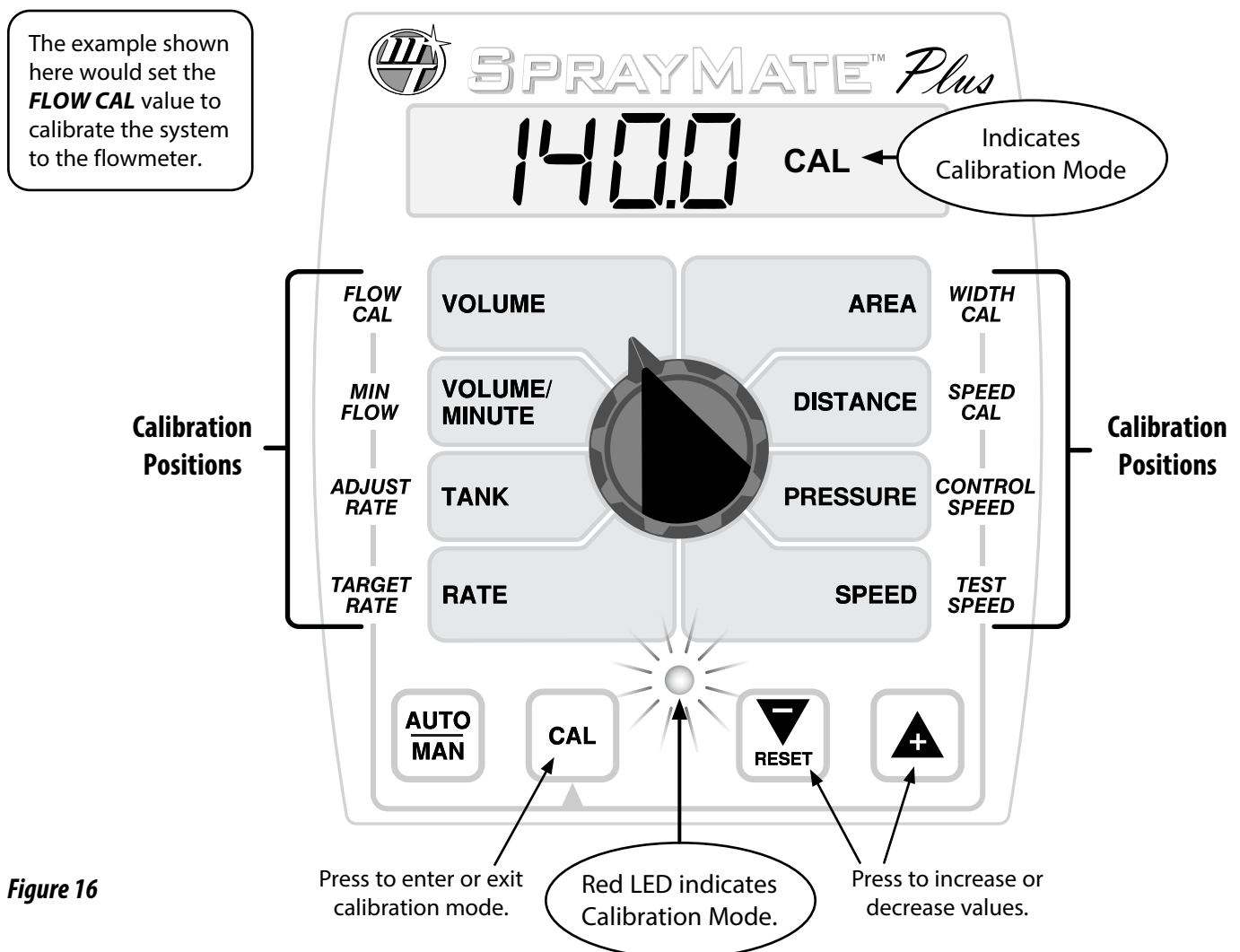

Figure 16

Restoring Default Calibration Values

To restore default calibration values and clear all counters (Tank, Volume, Area and Distance):

1. Change the UNITS value.
2. Turn the rotary knob to a different calibration page.
3. Turn the rotary knob back to UNITS.
4. Reset UNITS value to original choice.

Calibration (cont.)

Calibration Positions

FLOW CAL

This position calibrates the system to the flowmeter factory setting. The flowmeter is calibrated with water at the factory and assigned a "Liquid Cal" number. Adjust to this number - printed on the plastic tag attached to the flowmeter. See *Figure 17*.

This is a starting point only. If your spray solution has a specific gravity or viscosity different than water, flowmeter calibration should be done for the specific solution **Please refer to Fine-Tuning Flowmeter Calibration in Appendix D.**

Setting this number to 0 enables Pressure Based Control - see Appendix I.

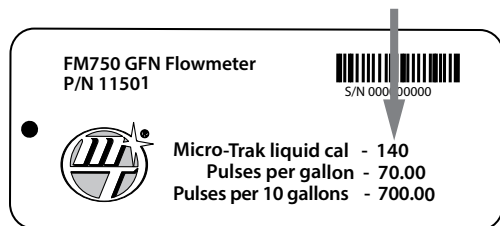

Figure 17

MIN FLOW

(OPTIONAL) - can be left at 0 (Off). This position is **only** used to maintain nozzle spray patterns by keeping the flow above the nozzle minimums. Use the recommended minimum flow rate for your nozzles multiplied by the total number of nozzles. Setting controls total minimum gallons per minute (lpm) flow.

DO NOT enter the actual flow of your spray application.

Caution: The system **WILL NOT** apply at a lower rate when spraying in AUTO. Higher settings can also cause system instability.

IMPORTANT NOTE: Over-application can occur with MIN FLOW on, if ground speed is too slow.

ADJUST RATE

Adjust the value for the desired amount of change to be used for making on-the-go rate adjustments. When operating in AUTO control, with RATE selected, pressing Increase/Decrease buttons will change the TARGET RATE by the amount entered for ADJUST RATE. This allows the operator to make incremental changes to the TARGET RATE. To disable this feature, simply enter a value of zero.

TARGET RATE

Adjust the value for the desired target application rate in gallons per acre (liters per hectare) or lbs. of N per acre (kgs of N per hectare). This is the application rate that the console will lock onto when operating in AUTO.

WIDTH CAL

Adjust the effective working width, in inches (meters) for each boom section. Enter a value of "0" (.000) for any unused sections. To adjust WIDTH CAL, quickly press and release the CAL key until the desired Section Number is on, then adjust the value.

The "working width" is the number of nozzles on the boom section multiplied by the nozzle spacing in inches (mm). Example: if you have 8 nozzles spaced at 12 inches, the working width of the boom section is 96 inches (8 X 12 = 96).

SPEED CAL

This position calibrates the system to the speed sensor. Adjust the value from the table of commonly used factors in *table 1* below or use the calibration procedure for magnetic sensors in Appendix B. NOTE: A fine-tuning procedure for verifying calibration factors can also be found in Appendix C.

Sensor	English Cal #	Metric Cal #	Hz/ MPH
GPS Speed			
Astro II & 5	.189	.48	46.56
SkyTrak (Std)	.150	.38	58.94
SkyTrak (MT)	.910	2.31	9.82
Dickey-john	.210	.53	42.00
John Deere (In-cab)	.197*	.50	44.70
Radar			
Vansco	.150	.38	58.90

Table 1

*value may range from .125 to .197

CONTROL SPEED

(OPTIONAL) This position adjusts valve response time to fine-tune the system. Example: increase Control Speed if the system is responding slowly to rate changes because of slow-moving valves. The default setting is -1 and range is -12 to 3.

NOTE: Exercise caution when increasing the valve response speed - the system may become unstable with higher control speed numbers entered.

TEST SPEED

(OPTIONAL) TEST SPEED is not a CALIBRATION setting. It internally simulates a speed signal to test the system without the vehicle moving. It allows you to test a spraying application with water to make certain that all of the equipment is operating properly while remaining stationary. Test speed is cancelled by exiting CAL. Test speed will not accumulate Distance/Area measurements and can be used if the console is locked.

Special Calibration

Special Calibration mode accesses important system parameters and settings.

The UNITS position must be set before changing any other Calibration or Special Calibration settings.

These settings enable or disable other setting options to adjust applicable parameters:

- **UNITS:** determines which unit of measurement is used
- **MATERIAL:** choice of H₂O or NH₃
- **OUTPUT TYPE** - PWM or STD: defines electronic drive signal for the control valve
- **MULTIFUNCTION:** defines MULTIFUNCTION output configuration

Special Calibration settings are accessed by selecting the row position with the main rotary knob and then pressing the CAL button to access Pages. Numbers displayed on the screen indicate which Page is active. Pressing the AUTO/MAN button once displays an abbreviated parameter title. Pressing **and holding** the AUTO/MAN button for 3 seconds enables Supervisor Lockout.

See **next page 24** for complete Special Calibration Steps and descriptions of Special Calibration settings. Note: Changing **UNITS** will load default CAL values and reset all counters to 0.

STD = Standard 12V operation only

PWM = PWM operation only

Page 5	Page 4	Page 3	Page 2	Page 1	
—	Three-way Valve Enable	Manual Enable	Hold Input Polarity	Tank Fill Level	
—	^{PWM} Flow @ Min. Pulse Width	Serial Protocol Type	Start Time	Tank Alarm Level	
—	^{PWM} Minimum Pulse Width	Minimum Alarm Speed	Valve Start % ^{PWM} / ^{STD} Auto Shutoff	Start Speed Time	
—	Agitation % ^{PWM} / ^{STD} Valve Polarity	Audible Alarm Enable	Auto Delay Time	Start Speed	

Right Side of Rotary Dial

	Page 1	Page 2	Page 3	Page 4	Page 5
AREA	Units	Pressure Offset	Multifunction Flow Trigger Threshold	^{PWM} PWM Frequency	Rate Alarm Threshold
DISTANCE	Material	Pressure Alarm Low	Multifunction Output	^{PWM} Flow @ Max. Pulse Width	Section Input Polarity
PRESSURE	Output Type PWM or STD	Pressure Alarm High	Flush Delay Time	^{PWM} Maximum Pulse Width	Fixed Minimum Flow
SPEED	Application ID	Pressure Full Scale	Flush Time	^{PWM} Closed/ Open Loop	—

Special Calibration (cont.)

SPECIAL CALIBRATION STEPS:

1. Turn ON console while pressing the CAL button - screen will display "SPEC", then 'CAL' and number 1 (Page 1).
2. Select a Special Calibration position using rotary knob. (See explanations of settings starting below)
3. Adjust Page 1 value or press the CAL button to access Pages 2-5.
4. Adjust value using Increase/Decrease buttons.
5. To exit Special Calibration without saving changes - turn console OFF.
6. To save changes and exit Special Calibration - press and hold the CAL button for 1 second - 'CAL' icon on screen will turn off and red LED light will turn off.

NOTE: Supervisor Lockout - Press and hold Auto/Man button 3 seconds to enter Supervisor Lockout control - use Increase/Decrease buttons to enable/disable this feature. Once locked, Special Calibration values can be viewed but not adjusted. Press CAL button to exit.

Special Calibration Settings - Page 1

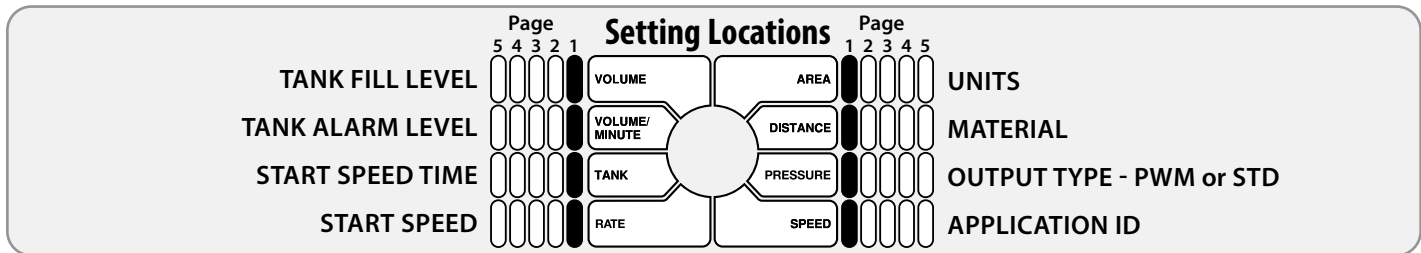

TANK FILL LEVEL

Location: PAGE 1 - VOLUME

Description: Adjust this setting to the known capacity of the tank. This value will be automatically entered when in Tank position by pressing the Increase (+) button. This can be set to OFF (0) up to 65535 max. Parameter units: English/Turf = gallons or pounds NH3, Metric = liters or kg NH3.

TANK ALARM LEVEL

Location: PAGE 1 - VOLUME/MINUTE

Description: Enables and adjusts value for Tank Alarm - set value to notify operator when level is reached. This can be set to OFF (0) or between 1 - 65535. Parameter units: English/Turf = gallons or pounds NH3, Metric = liters or kg NH3.

START SPEED TIME

Location: PAGE 1 - TANK

Description: Enables "Quick Start - Speed" function and defines the duration of the simulated speed - up to 6 seconds. See Appendix E for details. Setting to 0 (Off) will disable the function.

START SPEED

Location: PAGE 1 - RATE

Description: Enables "Quick Start - Speed" function and defines the intended simulated speed in MPH (km/H). See Appendix E for details. Setting to 0 (Off) will disable the function.

UNITS

Location: PAGE 1 - AREA

Description: Defines unit of measurement - English, Metric, or Turf - and loads system defaults. Changing UNITS setting also clears all counters. See Appendix J for system defaults.

MATERIAL

Location: PAGE 1 - DISTANCE

Description: Chooses material for application- H2O or NH3.

OUTPUT TYPE - PWM OR STD

Location: PAGE 1 - PRESSURE

Description: Choose PULSE (PWM) OR STD (reversing polarity DC) electronic drive signal for the control valve. The display will show PULSE or STD (also shown when console is powered up.)

APPLICATION ID

Location: PAGE 1 - SPEED

Description: Enter an ID number to identify the console. (This number could also represent an application or a vehicle.) If you connect the console to another device via serial port, the APPLICATION ID is included with the Totals Data List and Equipment List information. (Micro-Trak® protocol only)

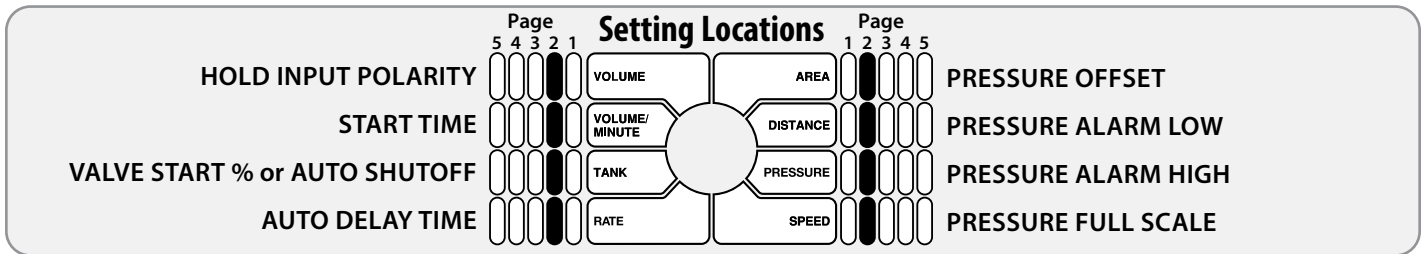

HOLD INPUT POLARITY

Location: PAGE 2 - VOLUME

Description: On Remote Run/Hold connection - allows user to reverse the circuit function. The default setting is CLOSED - meaning that SprayMate™ Plus will be in HOLD when the circuit is closed.

START TIME

Location: PAGE 2 - VOLUME/MINUTE

Description: Enables “Quick Start - Valve” function and defines the duration of the “Quick Start”. See Appendix E for details. Setting to 0 (Off) will disable the function.

VALVE START PERCENTAGE - PWM ONLY

Location: PAGE 2 - TANK

Description: Enables “Quick Start - Valve” function and defines the percentage of the PWM duty cycle during the “Quick Start - Valve” feature. See Appendix E for details.

AUTO SHUTOFF - STD ONLY

Location: PAGE 2 - TANK

Description: Enables Auto Shutoff feature - it runs the control valve towards minimum flow each time HOLD is selected, or when all (non-zero width) sections are turned off, or when in AUTO and ground speed goes to zero. Duration of Auto Shutoff feature is 18 seconds.

AUTO DELAY TIME

Location: PAGE 2 - RATE

Description: Enables and adjusts value for Auto Delay feature. When transitioning from HOLD to RUN, it provides time for motorized valves to operate and allows the flow to stabilize before AUTO control begins. This can be set to OFF (0) or between 1 - 4 seconds.

NOTE: If a “Quick Start” feature is enabled, then AUTO DELAY TIME should be set to 0.

PRESSURE OFFSET

Location: PAGE 2 - AREA

Description: Adjusts system to calculate pressure readings when using an “Absolute” style pressure sensor. Input Absolute Atmospheric Pressure in PSI (bar) for your location.

Note: Leave at 0 when using optional Micro-Trak pressure sensor(s) P/N 18757-18758, they are “Gauge” type sensors and self-adjust for ambient atmospheric pressure.

PRESSURE ALARM LOW

Location: PAGE 2 - DISTANCE

Description: Enables and adjusts value for Pressure Alarm - set value to notify operator when low level is reached. This can be set to OFF (0) or up to 50% of FULL SCALE setting. Parameter units: English/Turf = PSI, Metric = bar.

PRESSURE ALARM HIGH

Location: PAGE 2 - PRESSURE

Description: Enables and adjusts value for Pressure Alarm - set value to notify operator when high level is reached. This can be set to OFF (0) or up to 100% of FULL SCALE setting. Parameter units: English/Turf = PSI, Metric = bar.

PRESSURE FULL SCALE

Location: PAGE 2 - SPEED

Description: Displays and adjusts FULL SCALE (maximum) value for Pressure Sensor. Default setting is 150 PSI for Micro-Trak Pressure Sensor P/N 18757. Adjust it to 300 PSI for Micro-Trak P/N 18758. NOTE: This measurement is always rated in PSI - even if Metric units were specified in the UNITS Special Calibration setting.

Special Calibration Settings - Page 3

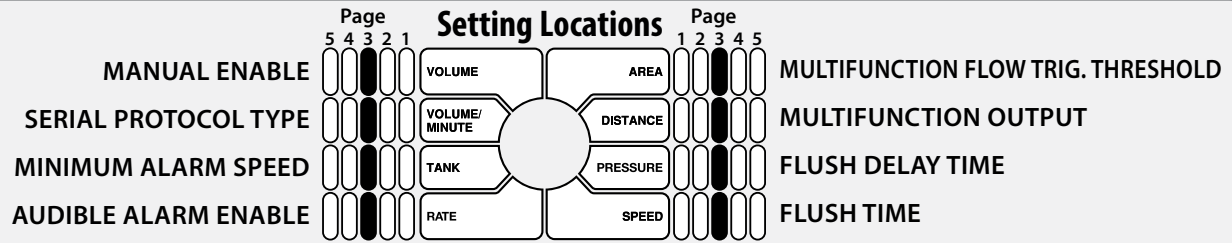

MANUAL ENABLE

Location: PAGE 3 - VOLUME

Description: Enables (ON) or disables (OFF) Manual Control mode. Disabling this function means the console will only run in AUTO mode and the AUTO/MAN switch will be inactive.

SERIAL PROTOCOL TYPE

Location: PAGE 3 - VOLUME/MINUTE

Description: Chooses serial protocol used for communicating VRA information through the serial port. Choices are Micro-Trak or Raven (model 660) Default is Micro-Trak protocol.

MINIMUM ALARM SPEED

Location: PAGE 3 - TANK

Description: Enables and adjusts a minimum speed threshold for the audible alarm - this prevents unneeded warnings while stopping and starting. This can be set to OFF (0) or from 0.1 to 99.9 mph (km/h). Affected alarms are Application Rate Error and Minimum Flow.

AUDIBLE ALARM ENABLE

Location: PAGE 3 - RATE

Description: Enables (ON) or disables (OFF) Audible Alarm function - allows user to operate system without hearing any system warnings. Flush cycle completion alert is not affected by this setting.

MULTIFUNCTION FLOW TRIG. THRESHOLD

Location: PAGE 3 - AREA

Description: When Multifunction output is set to Fixed Flow Trigger (F-FLO) or Proportional Flow Trigger (P-FLO), this adjusts the threshold value in Volume/Minute for activating the voltage output. The output will turn off if Volume/Minute is reduced to 95% of the threshold value. This fixed margin is maintained to reduce on/off cycling if system is operating at or near threshold setting.

F-FLO: Threshold value turns on power to Multifunction output based on the fixed total flow rate, regardless of active width.

P-FLO: Threshold value turns on power to Multifunction output based on flow rate, proportional to active width. Example: If the threshold is set to 10gpm while running only 2 out of 5 sections, the trigger would start output at 4gpm - $(2/5 \times 10)$.

MULTIFUNCTION OUTPUT

Location: PAGE 3 - DISTANCE

Description: Selects mode of 12VDC power sent to Multifunction Output connection on branch harness. Default setting this function is Master.

1. **OFF** = Always off
2. **ON** = Always on
3. **RELIEF VALVE** = On in Hold
4. **MASTER** = On in Run and at least 1 section on
(Note: there is a 1/2 second delay switching from HOLD to RUN)
5. **FLUSH** = Enables Flush cycle to purge chemicals from lines when switching from Run to Hold - see below
6. **F-FLO** = Fixed Flow Trigger - see above
7. **P-FLO** = Proportional Flow Trigger- see above

FLUSH DELAY TIME

Location: PAGE 3 - PRESSURE

Description: When Multifunction output is set to FLUSH, this enables and adjusts a time delay from the RUN/HOLD transition to the start of the Flush cycle. This can be set to OFF (0) or from 1-6 seconds.

FLUSH TIME

Location: PAGE 3 - SPEED

Description: When Multifunction output is set to FLUSH, this enables and adjusts the duration of the Flush cycle. This can be set to OFF (0) or from 1-12 seconds.

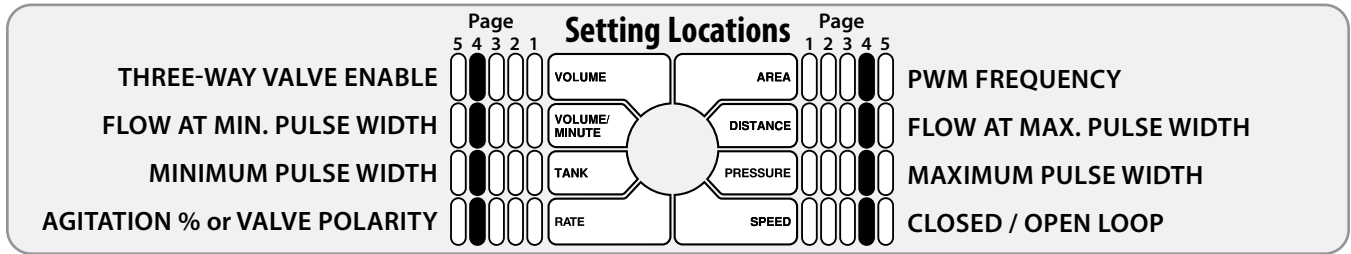

THREE-WAY VALVE ENABLE

Location: PAGE 4 - VOLUME

Description: Enables the use of Three-way Valves with the SprayMate™ Plus system. This setting changes the internal calculations for section totals so that flow in return lines to the tank (or to hydraulic system) is not included when sections are turned off.

FLOW AT MIN. PULSE WIDTH - PWM ONLY

Location: PAGE 4 - VOLUME/MINUTE

Description: Enables and adjusts value for Volume/Minute flow when the PWM valve is operating at minimum duty cycle. This can be set from 0.00 to 655.35 (This value must be smaller than the Flow At Maximum Pulse Width.)

Note: See Appendix H for more details.

MINIMUM PULSE WIDTH - PWM ONLY

Location: PAGE 4 - TANK

Description: In PWM Output, this adjusts value for Minimum Pulse Width. This setting can be useful to maintain hydraulic motor min. rpms or to ensure nozzle min. flows are maintained. This can be set from 0 to 100% (This value must be smaller than the Flow At Maximum Pulse Width.)

AGITATION PERCENTAGE - PWM ONLY

Location: PAGE 4 - RATE

Description: In PWM Output, this enables Tank Agitation when system is in Hold, and adjusts the desired duty cycle for the agitation. This can be set to OFF (0) or from 1 to 100%. Agitation is disabled during any calibration mode.

VALVE POLARITY - STD ONLY

Location: PAGE 4 - RATE

Description: In STD Output, this defines operation of the flow control valve - choose Bypass or Inline plumbing configuration. When using a Micro-Trak Electric Motor Driver, choose Bypass. Default setting is Bypass.

PWM FREQUENCY - PWM ONLY

Location: PAGE 4 - AREA

Description: In PWM Output, this adjusts value for PWM Frequency. This can be set from 50 to 500Hz. Consult your PWM device information for optimal frequency. Default frequency is 200Hz.

FLOW AT MAX. PULSE WIDTH - PWM ONLY

Location: PAGE 4 - DISTANCE

Description: Enables and adjusts value for Volume/Minute flow when the PWM valve is operating at maximum duty cycle. This can be set from 0.00 to 655.35 (This value must be larger than the Flow At Minimum Pulse Width.)

Note: See Appendix H for more details.

MAXIMUM PULSE WIDTH - PWM ONLY

Location: PAGE 4 - PRESSURE

Description: In PWM Output, this adjusts value for Maximum Pulse Width. This can be set from 0 to 100% (This value must be larger than the Flow At Minimum Pulse Width.)

CLOSED/OPEN LOOP - PWM ONLY

Location: PAGE 4 - SPEED

Description: In PWM Output, this selects Open or Closed Loop configuration. Closed Loop operation means using a flowmeter (or other sensing device) to calculate flow. Open Loop operation uses PWM parameters to calculate flow - useful when a flowmeter is not practical or flow rate is extremely low. Flow at Max. Pulse Width parameter must be set >0 before choosing Open Loop.

Note: See Appendix G for more details.

Special Calibration Settings - Page 5

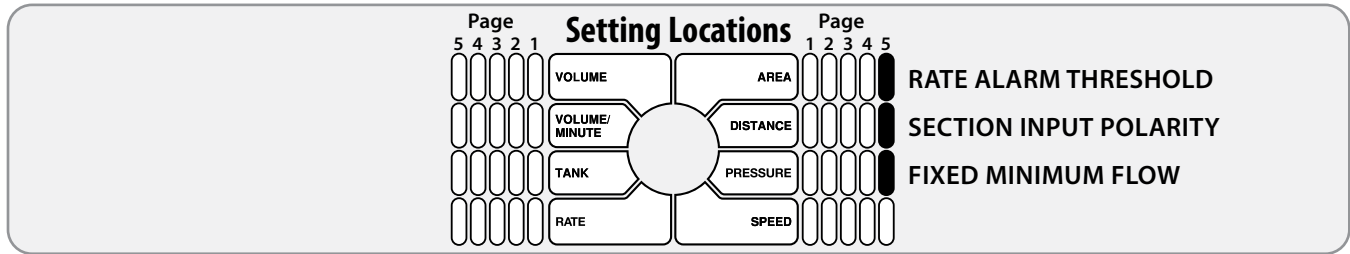

RATE ALARM THRESHOLD

Location: PAGE 5 - AREA

Description: Adjusts threshold value for the Rate Alarm - can be set from 10-30%. This value is the percentage of difference between the actual rate of application and the intended (target) rate. Default setting is 10%.

SECTION INPUT POLARITY

Location: PAGE 5 - DISTANCE

Description: This setting allows the user to reverse the polarity of section inputs. This may be useful when connecting a separate device to the SprayMate Plus system for automatic section control. Default is 12v.

FIXED MINIMUM FLOW

Location: PAGE 5 - PRESSURE

Description: Sets an absolute minimum flow for the system. This ensures that the flow rate is never less than the lowest range of the flowmeter - preventing the flowmeter from stalling. Default setting is 0 (off).

Make sure your system is properly calibrated before beginning to apply product. *We also recommend completion of the Pre Application System Checkout described on page 32 prior to beginning any operations.*

Manual Operation

This mode sets and maintains a steady flow rate (GPM) **not** affected by changes in vehicle speed. The overall application rate (GPA) will vary depending on speed (slow vehicle speed = increased application rate, fast speed = lower application rate.) Manual mode is most useful for system set up, spot applications, etc.

1. Press the AUTO/MAN button to select Manual mode ("MAN" icon will be displayed).
2. Adjust the flow rate by using the Increase/Decrease buttons to adjust the servo valve. The longer the buttons are held, the faster the valve will move to allow both rapid movement and fine adjustments.

Note: Manual control can be disabled by changing the MANUAL ENABLE setting in Special Calibrate.

IN RUN:

Manual rate adjust can be done while the rotary knob is in either the RATE or VOLUME/MINUTE position.

IN HOLD:

If the console is in HOLD, or if all section valves are OFF, the rotary knob must be in the VOLUME/MINUTE position to adjust the servo valve using the Increase/Decrease buttons. In that position only, the servo valve can be adjusted without any section valves on, and the flow rate (GPM or LPM) can be monitored. This can be useful for system pressure tests, etc. The above applies only when using a Standard (Std) control valve. A PWM (PULSE) control valve is always Off when in HOLD.

Automatic Operation

This mode sets and maintains a steady application rate (GPA) - unaffected by changes in speed or section switching.

1. Press the AUTO/MAN button to select Automatic mode ("AUTO" icon will be displayed).
2. Switch on the desired number of boom sections.
3. Switch the RUN/HOLD switch to RUN.
4. Drive vehicle. (Speed signal will activate system.)

Use the Section switches, the RUN/HOLD switch or remote RUN/HOLD sensor to Start or Stop application at any time.

ON-THE-GO RATE ADJUSTMENTS

To adjust the application rate, turn rotary knob to the RATE position and press the **Increase/Decrease** buttons. The increment of this change is set in the ADJUST RATE position in Calibration. For example, if the calibrated TARGET RATE = 20.0 GPA and ADJUST RATE = 1.0 GPA, pressing the **Increase** key once will increase the target rate from 20.0 to 21.0. The display will momentarily show the new TARGET (21.0) for two seconds before it resumes showing the ACTUAL application rate. The "adjusted" target rate is maintained until console power is turned off. NOTE: The target rate may also be adjusted while in HOLD.

Care and Maintenance of your SprayMate™Plus

- Store the console in a cool dry location during the off-season.
- Do NOT allow water or other liquids to enter the case.

Operation (cont.)

Console Controls

ON/OFF SWITCH

When the SprayMate Plus console is turned on (except when starting SPECIAL CALIBRATE) the display shows the following information for approximately 1 second each:

- Number of hours it has operated.
- Software Part Number
- Software Revision Letter
- Drive type for control valve (“PULSE” or “5t d”)

NOTE: If FTW option is enabled (using Three Way valves) then “3WAY” is also shown.

DISPLAY

During normal operation, the console will display information relevant to the rotary knob position. During application, the rotary knob is commonly left on the RATE position where the Application Rate and section numbers are displayed.

RUN/HOLD SWITCH

The RUN/HOLD is the master switch for turning all (active) boom sections on and off. This function can be done either manually with the included RUN/HOLD switch, or automatically, using the optional remote RUN/HOLD sensor kit (implement switch).

SECTION SWITCHES

Section switches control the three boom sections. The console accumulates AREA data based on the calibrated section widths. When a section is turned OFF, its width is subtracted from the total width and is not included in accumulated area totals. RATE is automatically compensated when sections are turned on and off. If the rotary switch is in the RATE position, the numbers 1, 2, or 3 are visible when corresponding section is ON.

AUTO/MAN

This button switches the operating mode of the system from fully automatic to manual control. The two control modes are indicated by the ‘AUTO’ and ‘MAN’ icons on the display.

CAL

This button is used to enter and exit calibration modes. It is also sometimes used to navigate between choices in other modes, as described in those areas of the manual.

INCREASE/DECREASE

APPLICATION RATE ADJUST:

In the RATE position, these buttons are used to increase or decrease the application rate. For more details refer to the ‘Manual Operation’ and ‘Automatic Operation’ sections on the previous page.

CALIBRATION PARAMETER ADJUST:

While in calibration the Increase/Decrease buttons are used to increase or decrease values, or select settings, as described in the Calibration and “Special” Calibration sections.

ADDITIONAL USES:

- Select (or Reset) Counters. Reference the ‘Resetting System Counter’ section.
- Tank Level adjust, or preset refill (see TANK).
- Start LIVE Cal (PWM only) mode (see “Live Cal” section).

WARNING LIGHT

The console is equipped with a RED warning light. The light will automatically turn on and flash when the actual application is plus or minus 10 percent (*see NOTE*) of the calibrated target rate, or if the TANK alarm feature is activated and the tank is below the set point (display will also flash “FILL” message), if PRESSURE reading is too high or too low, and if MINIMUM FLOW warning is activated.

***NOTE:** This percentage can be adjusted via the ‘Rate Alarm Threshold’ parameter in “Special” Cal.

If the light stays on while in AUTO, refer to the troubleshooting section of this manual. The RED warning light will also be illuminated when calibration mode is active on the console.

AUDIBLE ALARM

The Audible Alarm sounds during the following conditions:

- The Application Rate Error is greater than 10% (*Rate Alarm Threshold) for 3 seconds (continuously) when in AUTO, and the Ground Speed is above the (*Minimum Alarm Speed).
- The calculated Tank level is below minimum level (*Tank Alarm Level).
- PRESSURE is above or below specified limits.

***Note:** Adjustable in “Special” Calibration.

Operation (cont.)

Additional System Features

SERIAL PORT (VRA)

The SprayMate™ Plus has a 9-pin serial connector on the back panel which allows it to be connected to a “GPS / Mapping Controller” (GMC) that supports 3rd Party controllers using a RS232 serial connection. Once the GMC is properly setup, the SprayMate™ Plus can then accept variable target rates from a prescription map. If the GMC does not include ‘Micro-Trak’ as a supported serial controller, then the Raven 660 protocol may be used instead (See Special Cal parameter ‘Serial Protocol Type’ page 26).

VRA Status Indicator (‘V’ icon)

While in AUTO and in the RATE position, the ‘V’ icon is lit as long as the console is receiving target rates from the GMC. The ‘V’ icon disappears if a new rate command has not been received within 2 seconds. This can be useful to troubleshoot connection issues.

VARIABLE RATE APPLICATION

In order to accept VRA commands, the console must be operating in AUTO, the GMC is in control of the application rate and the console will automatically control to the prescribed target rate. If the connection is lost, console will revert back to internal console rate.

TARGET ZERO HOLD

When outside of the prescribed mapping area, most GMC’s have a setting that allows Target Rate = 0 to be sent. Whenever a target rate of zero is received, the SprayMate™ Plus will go into HOLD (stop spraying) and if in the RATE position it will show “PHold” (Prescription HOLD).

VRA “OVERRIDE”

There may be times when the operator needs to apply more or less than the prescribed rate (or override Target Hold). To override, hold the **Increase** button for 1 second while in the RATE position (‘V’ icon should disappear). The SprayMate™ Plus now ignores all VRA commands, and starts using its own calibrated TARGET RATE, which can then be further adjusted by momentarily pressing the **Increase** or **Decrease** buttons. To exit override, simply press and hold the **Increase** button for 1 second until the ‘V’ icon reappears, and the console will resume using the prescribed rate from the GMC.

“AS APPLIED” MAPPING

Some GMC’s may also be run without using a prescription map. In this case, the GMC does not send any target rates, it simply records the actual rate applied, and which sections are On or Off, as reported by the SprayMate™ Plus console.

EMERGENCY STOP (No Flow)

If the Flow signal is lost while running in AUTO, the system will automatically increase the flow to maximum to compensate for the low Application Rate. This can quickly create a severe over-application. The Emergency Stop feature helps prevent over-application and chemical spills if the Flow signal is lost.

If the Flow signal is missing for 15 seconds or more, it automatically stops the flow (turns section outputs off, closes control valve) and displays “noFLO” to alert the operator. The system will remain disabled until Run/Hold is switched to Hold, or power is cycled off and on, or CALIBRATE is entered and exited.

Note: It is possible to override this safety feature. See the ‘Closed Loop Override’ section in Appendix F.

COUNTER RESET

The VOLUME, AREA, & DISTANCE data counters can be reset as needed. The VOLUME and AREA data have three separate sets of counters and are linked together (clearing VOLUME will also clear AREA etc.)

To reset a counter:

1. Switch system to HOLD.
2. Turn rotary knob to desired position.
3. Select which data set you wish to clear by pressing the **Increase** button. The number of data set is shown on display. (Does not apply to DISTANCE counter)
4. Press and hold **Decrease** button. Display will show “CLEAR” and then “.0”.

NOTE: If the console is locked, only Data Set 1 can be cleared.

SUPERVISOR LOCKOUT

When activated, this prevents clearing the data counters and blocks changes to calibration settings. Supervisor Lockout mode can be entered by holding down **Auto/Man** button for 3 seconds while in Special Calibration mode. Use the **Increase/Decrease** buttons to enable/disable feature. Press **CAL** button to exit.

Pre-Field System Checkout

Before beginning actual spraying, perform the following “Pre-Field” procedure to ensure that your valve settings, nozzle selection and desired speed range will allow the SprayMate™ Plus to provide the required application control. This procedure should be repeated for each new nozzle selection and/or application rate.

Refer to your nozzle selection guide to find a nozzle suitable to your speed and rate range.

OPTIMIZING LIQUID FLOW RATE

For best performance, adjust the output of the pump so the control valve is operating mid-position. If the valve is forced to operate almost fully open or fully closed, erratic flow control will result. This can be achieved by adjusting the hydraulic fluid flow to the hydraulic motor on the pump, increasing flow through a bypass line, or installing a throttling valve to the boom between the bypass line and the flowmeter.

The following procedure will balance the liquid flow to provide smooth, accurate flow control.

1. Fill your sprayer tank with clean water - **DO NOT** use chemicals until the entire system is completely checked out and operating properly.
2. Start pump; bring up to normal operating RPM. Do NOT exceed safe system pressure.
3. Power up SprayMate™ Plus and switch system to **HOLD**.
4. Enter Calibration mode by pressing and holding **CAL** button.
5. Turn rotary knob to TEST SPEED position.
6. Enter the fastest speed you'll be driving while applying product - use Increase/Decrease buttons to adjust number.
7. Select Manual control using **Auto/Man** switch.
8. Turn all boom section switches on.
9. Turn rotary knob to RATE position. The CAL icon will flash to indicate simulated ground speed mode.
10. Press and hold **Increase** button to maximize flow.
(May take 10+ seconds depending on valve)
11. If installed, adjust agitation valve for desired agitation amount.
12. If the rate displayed is more than 15% over your desired application rate, reduce liquid flow by one or more of the following:
 - a. Slow down pump RPM
 - b. Open a return or agitation valve to reduce flow through the flowmeter.
 - c. Close a throttling valve (controls output to the sections) to choke down pump output.
13. If the rate displayed is less than your desired application rate, increase liquid flow by one or more of the following:
 - a. Increase pump RPM
 - b. Close a return or agitation valve to increase flow through flowmeter.
 - c. Open a throttling valve (controls output to sections) to increase pump output.

Troubleshooting Messages/Warnings

bAd ^{CAL}	Indicates a corrupt calibration value. Can only be cleared by entering Calibration or Special Calibration modes, checking and/or changing settings and exiting to save.
CLEAR	The message alerts the user that the currently selected counter will be cleared if the reset button is held for 2 seconds. Also serves as a reminder to use "+" button to select counters.
Error	Error message displayed if Open Loop is selected when Flow @ Max. PW = 0. Also shown in Open Loop and Override if Flow @ Max. PW < Flow @ Min. PW
FILL	Tank level is below 'Tank Alarm Setting'.
h.PS I	High Pressure warning message. The input pressure exceeds the specified High Pressure Limit.
Hold	Visible in channel rate window. Channel is ON and Run/Hold switch is set to Hold.
Lo P	Low Power. Check all power and ground connections.
LoPS I	Low Pressure warning message. The input pressure is less than the specified Low Pressure Limit.
no FLO	(Alternating no/Flo) Flow Signal not detected. Check flowmeter and verify there is liquid flow and the tank is not empty. After 15 seconds, system will disable (Emergency Stop).
no PS I	In Pressure Control mode - no pressure detected at sensor. After 15 seconds, system will disable (Emergency Stop).
no SPEED	(Alternating no/Speed) Speed Signal not detected - visible in RATE position.
OFF	Visible in channel rate window. Channel is OFF.
OPE n	In Pressure Control mode - no pressure sensor detected (circuit is "open").
PHoLd	Prescription Hold - GPS/Mapping controller is sending '0' rate command.
PULSE	System configured for Pulse Width Modulation 12V drive mode. Message is shown during start-up screens.
rHoLd	Remote Run/Hold is connected and set to "Hold".
SPEC	Special Calibration Mode is active.
Std	System configured for Standard 12V drive mode. Message is shown during start-up screens.
V CAL	The Live Calibration mode (PWM Only) is active.
3WAY	(3 WAY) The system is configured for three-way valves. Message is shown during start-up screens.
99999	Counters (DISTANCE or AREA or VOLUME) have reached their maximum. RESET (see page 25) to clear counters and resume counting.
-----	Indicates an unused Special Calibrate or Live Calibrate position.

Indicator LED

Lit when console is in Calibration or Special Calibration mode.

Rate Warning LEDs

Channel Rate Warning LEDs flash when the Rate error is over 10%, Volume/Minute is below the Minimum, Tank level is at less than Tank Set Point, or Pressure readings are over/under set alarm limits.

Audible Alarm

Alarm will sound 3X if Alarm Enable is ON and the Tank Level is below minimum, Application Rate error rate is greater than 10%, or if Pressure is too low or too high for prescribed limits.

Troubleshooting (cont.)

General

All SprayMate™ Plus consoles, flowmeters and servo valves are tested prior to packaging, so unless there has been damage in shipment you can be confident that everything will be operational when you receive it.

However, if you do encounter a problem that appears to be related to equipment failure, **PLEASE DO NOT OPEN THE CONSOLE**. Your system is protected by a warranty, and Micro-Trak® will gladly correct any defect.

Many problems are the result of mistakes in installation or operation. Before returning any parts for service, carefully check your installation and review the operating instructions. *For easy-to-follow guidelines, refer to the troubleshooting section which follows.*

CONSOLE APPEARS DEAD

Using a test light or meter, check for 12 volts at the power source. Also check for damaged power cable or reversed terminals. *(Console requires 12 volts for proper operation)*. Check connections of ignition or power switch.

SPEED IS ALWAYS ZERO OR ERRATIC

Check for properly calibrated Speed Cal.

Review speed sensor installation. Check for proper mounting, alignment and spacing of speed sensor in relationship to magnet assembly. Make sure magnet polarities are alternated. Also check cable for breaks or incomplete connection.

DISTANCE COUNT IS INACCURATE

Speed Cal was incorrectly measured or entered. Review calibration, re-adjust and test.

AREA COUNT IS INACCURATE

Implement width or Speed Cal was measured or programmed incorrectly. Go back through the original procedures, make changes, and test for acre (hectare) count again. **(Make sure no width is entered for unused boom sections.)** Verify accuracy with formula:

Acres = Distance x Width in feet ÷ 43560

Hectares = Distance x Width in meters ÷ 10,000

NO READOUT OF GALLONS (LITERS), OR GALLONS (LITERS) PER MINUTE

Check to see that the sprayer pump and equipment are operating properly. If liquid is moving through the line, check the flow sensor to be sure it is screwed all the way into the flowmeter.

Check to see that a FLOW CAL number has been entered. Also check cable for breaks or incomplete connection.

If the flowmeter is new or has not been used for a long period of time, the turbine may be sticky. Flushing the system out with water should make the turbine spin freely.

Flow rate may be too low to register a reading, or foreign material may be lodged in the flowmeter.

BOOM SHUT-OFF

If you are in AUTO with no speed, all the boom sections will shut-off.

TOTAL LIQUID USED IS INACCURATE

This may result from an incorrectly-entered "FLOW CAL" value. Check the number stamped on the flowmeter tag, and be sure this is entered in the console's "FLOW CAL" position. If the meter has been used for some time, wear may have changed the Flow Cal value. *See Fine-Tuning Flowmeter Calibration in Appendix D.*

Check the mounting position of the flowmeter. With lower flow rates, the meter should be mounted vertically. Also check to see that the flow sensor is screwed all the way into the flowmeter.

Other causes may be inaccurate sprayer tank markings, a flow rate too low to register, or foreign material lodged in the flowmeter.

CONSOLE IS ERRATIC IN OPERATION

If you have a two-way radio, it may be mounted too close to the console. Keep all SprayMate™ Plus cables away from the radio, its antenna and power cable.

Ignition wires may be causing the console to malfunction. Keep SprayMate™ Plus cables away from ignition wires, or install ignition suppressor.

Reroute all cable away from electric solenoids, air conditioning clutches and similar equipment.

Check the CONTROL SPEED calibration number in Calibration. If the RATE tends to overshoot or oscillate, the CONTROL SPEED setting may be too high for the control valve being used; reduce the CONTROL SPEED setting by 1 (range is -12 to +3).

DISPLAYED MEASUREMENTS DO NOT MAKE SENSE

The console may be in the incorrect measurement mode (English or metric).

DISPLAY READS "99999"

DISTANCE, AREA, and VOLUME counters read 99999 when they have exceeded their maximum count. Reset to zero to resume counting.

SYSTEM OPERATION (CONTROL) IS SLUGGISH IN AUTOMATIC MODE

Check the CONTROL SPEED setting in Calibration. If using a slow valve (4 seconds or more, close to open) increase the CONTROL SPEED setting.

Troubleshooting (cont.)

Checking Individual Components

CONSOLE

The best ways to field test a console are to connect it to a harness on a vehicle with a known working console or assess it on a Micro-Trak® demonstration display.

HARNESS

The harness can be checked using an ohmmeter or continuity tester. The main wiring diagram shows the pin out of all connectors. *See pages 7 and 11.*

ELECTRICAL INTERFERENCE

Erratic operation of the system may be the result of electrical interference from ignition wires or inductive loads (electrical clutch, fan, solenoid, etc.). Always try to route wires as far away from suspect areas as possible. If problems occur, you may need to relocate the console and/or wiring harness, or install a noise suppressor.

POWER

Check power source with an electrical meter or test light. If there is no power, trace cable toward battery looking for breaks. Also check any fuses or circuit breakers that supply power to the console.

ACCESSORY POWER

The speed, flow and run/hold cables all have an accessory power wire. Check for 12 volts between B and C of these connectors. If power is not present, make sure the accessory power wire is not open or shorted to ground or to another wire. If this wire has a problem, the console may exhibit erratic behavior or not function at all.

RUN/HOLD HALL-EFFECT SENSOR

Caution: Improper connection or voltage could damage the Hall-Effect sensor. The Hall-effect sensor works similar to a reed switch, but requires power in order to function. This particular type of Hall-effect sensor “closes” when near the south pole of a magnet and is otherwise “open”.

Ground pin C (black) and connect clean 12 volts to pin B (white) of the Hall-effect sensor cable. Connect the positive lead (red) of an ohmmeter or continuity tester to pin A (red) and the negative lead (black) of the ohmmeter or continuity tester to pin C (black) of the Hall-effect sensor cable.

Holding the tip of the sensor up to the south pole of a magnet should result in a very low resistance (around 300 ohms). Taking the sensor away from the magnet should result in a very high resistance (infinite).

MAGNETIC HALL-EFFECT SPEED AND FLOW SENSORS

Caution: Improper connection or voltage could damage the Hall-effect sensor. The Hall-effect sensor functions much like a reed switch, but requires 12VDC to operate. Also, the Hall-effect sensor requires alternating magnetic polarities in order to switch. This means that the north pole of a magnet will “open” the circuit and the south pole will “close” it.

Ground pin C (black) and connect clean 12 volts to pin B (white) of the Hall-effect sensor cable. Connect the positive lead (red) of an ohmmeter or continuity tester to pin A (red) and the negative lead (black) of the ohmmeter or continuity tester to pin C of the Hall-effect sensor cable.

Holding the tip of the sensor up to the north pole of a magnet should result in a very high resistance (infinite), while holding the tip of the sensor up to the south pole of a magnet should result in a very low resistance (around 300 ohms).

VANSCO RADAR SPEED SENSOR

1. Carefully check your installation and operating instructions. The following are tips for troubleshooting;
2. Disconnect the radar adapter cable from the console Speed connection.
3. Check for 12 VDC between pins B and C of the console Speed connection. If not present, console or harness may be defective.
4. Using a jumper wire (paper clip bent into a “U”), rapidly short together positions A and C of the console Speed connection several times. The console should respond with some speed reading. If not, the console or harness may be defective.
5. Reconnect the radar adapter cable to the console Speed connection.
6. Disconnect the radar from the radar adapter cable.
7. Check for 12 VDC between pins 1 and 3 of the radar adapter connector. If it is not present but was present in step 2, the radar adapter cable may be defective.
8. Using a jumper wire (paper clip bent into a “U”), rapidly short together positions 2 and 3 of the radar connector (round 4-pin) several times. The console should respond with some speed reading. If not but had a reading in step 3, the radar adapter cable may be defective.
9. If system passes all above tests, the radar may be defective.

Troubleshooting (cont.)

Checking Console Inputs

CONSOLE INPUTS

If there is no response from any of the following tests, refer to the main wiring diagram to locate the next connector in line toward the console and repeat the test at that connector. If there is a response at that connector, the problem may be in the cable between the two connectors (or the connectors themselves).

SPEED INPUT

Turn rotary switch to the SPEED position and disconnect the speed sensor cable from the speed connection. Use a meter to check for voltage. It should read 12V between pins B and C and 9V between pins A and C.

See Figure 18.

FLOW INPUT

Turn rotary switch to VOLUME/MINUTE and disconnect the flow sensor cable from the main harness flow connection. Use a meter to check for voltage. It should read 12V between pins B and C and 9V between pins A and C.

See Figure 18.

REMOTE RUN/HOLD INPUT

Disconnect the remote run/hold sensor from the main harness Remote Run/Hold connection. Use a meter to check for voltage. It should read 12V between pins B and C and 9V between pins A and C.

See Figure 18.

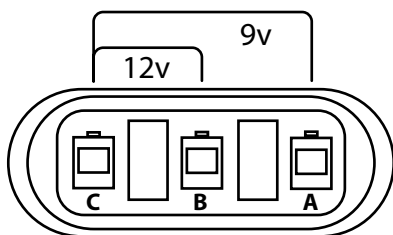

Figure 18 Three-Pin Connector Testing

Note: If a multi-meter is not available, find a small piece of wire to use as a jumper. Short across pins A and C several times quickly to send a signal to the console. If the cable is functional, the console should respond with a reading.

FLOWMETER

Shaking the Flowmeter end to end should produce a “rattling” sound (shaft end play). Blowing in the meter from either end should spin the turbine freely. If the turbine spins freely but the meter will not register flow with a known working sensor, the turbine may be defective.

SERVO VALVE CONTROL SIGNAL

With the console turned ON, put the console in MANUAL mode, place the remote Run/Hold switch in the RUN position and turn at least one section switch to ON. Using a voltmeter or simple test light, check from a good frame ground to each of the servo wires on the main harness connector. You should get 0 volts on each wire. Holding the **Increase** button should cause the RED wire to pulse toward 12 volts (light will pulse). Holding the **Decrease** button should cause the BLACK wire to pulse toward 12 volts (light will pulse).

SERVO VALVE

The best way to test the servo valve is with a known working console. Turn console ON, put the console in MANUAL mode, place the remote Run/Hold in the RUN position, turn the rotary switch to RATE and turn at least one boom section switch to ON. With the servo valve connected to the servo valve lead on the main harness, holding the **Increase** button should close the servo valve and holding the **Decrease** button should open the servo valve (if plumbing is configured for Bypass operation). The servo valve should operate smoothly in both directions, from fully open to fully closed.

You may also test a servo valve with a 9V battery. Connecting the battery to each terminal on the servo valve should cause the servo valve to run in one direction. Reversing the battery connections should cause the servo valve to run the other direction. The servo valve should operate smoothly in both directions, from fully open to fully closed.

PLUMBING

System plumbing is a critical factor in obtaining optimal performance from your SprayMate™ Plus system. The chart on the next page may help you determine what area of the plumbing is causing your problem. It is assumed that your plumbing functionally matches the system diagram and that the servo valve and flowmeter are installed correctly and functioning. In addition, make certain that you have selected and installed the correct spray tips for the application, speed and spray rate that you intend to maintain. Do not overlook leaky fittings and hoses, pinched hoses and plugged or worn nozzles.

Plumbing Troubleshooting Chart

SYMPTOM	POSSIBLE CAUSE	POSSIBLE SOLUTION
System loses pressure in MANUAL	Pump Air-lock	<ul style="list-style-type: none"> • Clean strainer • Install larger hoses
Insufficient pressure adjustment in MANUAL	Too much flow restriction in servo loop	<ul style="list-style-type: none"> • Install larger hoses and fittings • Remove sharp bends in plumbing
System pressure too low in MANUAL	<ul style="list-style-type: none"> • Pump starved or too small • Excessive tank agitation • Incorrectly positioned throttle, range adjust, or pressure relief valves 	<ul style="list-style-type: none"> • Install larger hoses/replace pump. • Reduce tank agitation • Adjust valves
Pressure, Speed and Spray Rate don't correspond to charts	<ul style="list-style-type: none"> • Inaccurate pressure reading • Dirty or worn spray tips 	<ul style="list-style-type: none"> • Use a different gauge and check each boom. • Clean or replace spray tips
Pressure excessive in AUTO	<ul style="list-style-type: none"> • Minimum flow rate is set too high • Incorrect Inline/Bypass setting 	<ul style="list-style-type: none"> • Re-calibrate system • Change Inline/Bypass setting
Pressure fluctuates in AUTO	<ul style="list-style-type: none"> • Sagging or kinked hoses • Throttle or range valve restricting flow • Pump starved or too small • Control Speed calibration number too high - making the valve react excessively 	<ul style="list-style-type: none"> • Support or replace hoses • Adjust throttle and range valves • Install larger hoses • Install larger pump • Clean strainer • Reduce Control Speed setting

Table 2

Plumbing Guidelines

This section details important factors for ideal system performance. The system diagrams (*See pages 14 - 15*) show optimal plumbing configurations for the SprayMate™ Plus.

PRESSURE DROPS

All hose, valves and fittings (especially elbows) can cause undesirable pressure losses. Here are a few points:

1. Use hoses as large in diameter as practical.
2. Avoid excessive hose length.
3. Avoid sharp bends in hose whenever possible.
4. Use minimum number of fittings.
5. Use full port valves or the next larger size valve.
6. Support and fasten hose runs to avoid sagging and kinking.

HOSE DIAMETER

Hose diameter must be suitably large to maximize flow between system components - this includes connecting lines joining the flowmeter, servo valve, and agitation line. Undersized plumbing can prevent reaching target application rate and also contribute to system instability.

RANGE ADJUST VALVE

The range adjust valve is required when the pump is much larger than necessary. When the range valve is opened, some of the liquid will be bypassed around the pump to avoid "overloading" the rest of the system. The setting of the range adjust valve is determined by the throttle valve. **Start with the range valve fully closed and perform the Pre-Field System Checkout on page 32.** If the throttle valve needs to be more than two thirds closed, open the Range valve slightly and perform the Pre-Field System Checkout again.

THROTTLE VALVE

The throttle valve limits your high end to maximize servo performance. Start with throttle valve fully open and perform the **Pre-Field System Checkout on page 32.**

Appendices

Appendix A - Remote Run/Hold Kit Installation

The Remote Run/Hold Sensor has a black body and joins to the branch harness cable labeled "Remote R/H". It is used as an implement switch and automatically activates the Run/Hold function as implement is raised and lowered. The Remote Run/Hold sensor only responds to the south pole side of the magnets - marked with a dashed line.

Installation

1. Choose magnet location on lever or some part of the equipment that moves when the implement is raised and lowered - be sure location will not interfere with any moving parts. See *figures 19 and 20* at right.
2. Clean area of all dirt and oil residue.
3. Fasten included magnet(s) by peeling off protective paper and pressing firmly in place.
4. Attach mounting bracket to a stationary part of the implement, centered over the magnet area. (It may be necessary to modify the bracket to fit.)
5. Mount sensor to bracket, leaving a 1/8" to 3/8" air gap between tip of sensor and magnet.
6. Route cabling to console avoiding areas of abrasion or excessive heat. Fasten wires using included ties.

NOTE: Additional extension cables are available in 5, 10, 15, 20, 25, and 50 ft. lengths.

NOTE: Run/Hold input polarity is reversible with the SprayMate™ Plus. See page 25 - 'Hold Input Polarity' in "Special" Calibration.

Remote Run/Hold Kit - P/N 01535

Includes:

- Run/Hold Sensor w/ 3-pin Metri Pack conn.
- 10' extension cable
- 2 magnets w/foam adhesive tape
- Mounting bracket
- (2) 1/4"-20 machine screws + nuts
- (2) 1/4" lock washers
- (2) 1/4" threaded hex screws

Lift Wheel Mounting

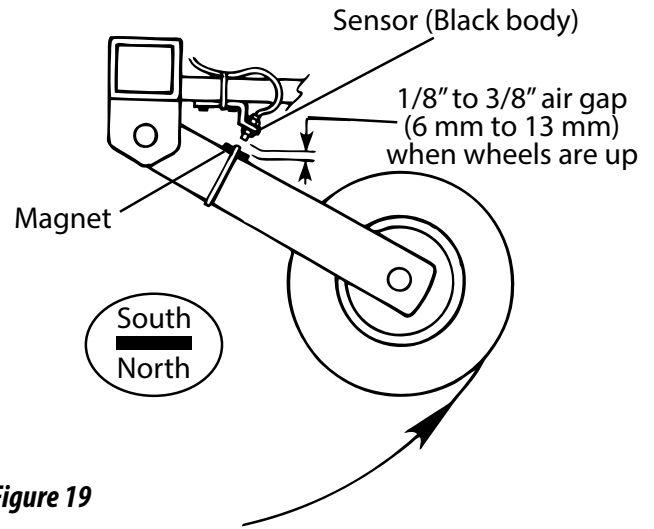

Figure 19

Hydraulic Cylinder Mounting

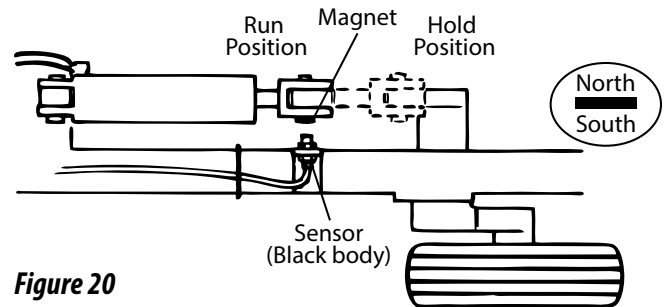

Figure 20

Remote Run sensor on hydraulic cylinder. Magnet and sensor are aligned when equipment is lowered and operating.

Appendix B - Magnetic Speed Sensor Installation

Magnets

The number of magnets that must be used depends on the size of your tire and where you mount the sensor. On tractor or implement wheels the general rule of thumb is one magnet for each wheel bolt (minimum of two, and always an even number). For drive shafts or small wheels (ATV's), two magnets are usually adequate.

Some installations may require that more than two magnets be installed. To determine the number of magnets required, measure the distance traveled of one revolution of the sensor equipped wheel in inches (meters). Divide that measurement by 20 for English and Turf units, or by .5 for Metric units, and then round up to the nearest even number (always use an even number of magnets). That number will be the minimum number of magnets required for the installation.

Example in English/Turf units: If your revolution measurement is 97 inches, dividing that number by 20 gives you a value of 4.85. Rounding 4.85 up to the nearest even number is 6. For this example, the minimum number of magnets required is 6.

Example in Metric units: If your revolution measurement is 2.5 meters, dividing that number by .5 gives you a value of 5. Rounding 5 up to the nearest even number is 6. For this example, the minimum number of magnets required is 6.

The magnets provided by Micro-Trak® are marked with a punched dashed line on the SOUTH pole side of the magnet. *See Figure 21.*

Always use an even number of magnets, and always alternate the polarities of the magnets as you go around the wheel hub or drive shaft.

To install, mount the first magnet with the SOUTH pole side (dashed line) facing toward the hub or shaft. Mount the second magnet with the NORTH pole side facing toward the hub or shaft. *See Figure 22.*

For proper operation, the magnets must be evenly spaced around the wheel or drive shaft. The magnets must be at least 1" apart. *See Figure 23.*

Attaching Magnets

The magnets are attached to a wheel hub or drive shaft and the speed sensor is mounted directly over the magnet. When the wheel or drive shaft begins turning, a speed impulse is sent to the SprayMate™ Plus console every time a magnet passes by the tip of the speed sensor. For the speed sensor to operate properly, the spacing between the magnets and the tip of the sensor must always remain constant. Before permanently mounting any parts, be sure that the location you have selected will meet the following requirements. *See Figure 24.*

NOTE: Magnets must alternate in polarity.

Locate the Following Parts

- Speed Sensor Cable (Green Body)
- Mounting "L" Bracket
- Magnets
- Cable Ties

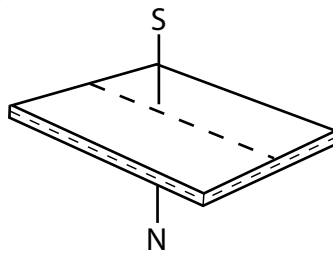

Figure 21

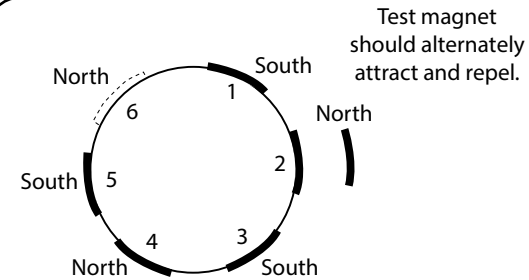

Figure 22

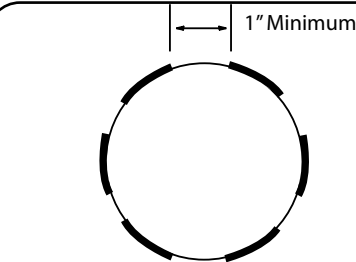

Figure 23

NOTE: Magnets may be attached mechanically as shown or adhered with epoxy or other high quality adhesive. When using adhesive, thoroughly clean the area of dirt and oil.

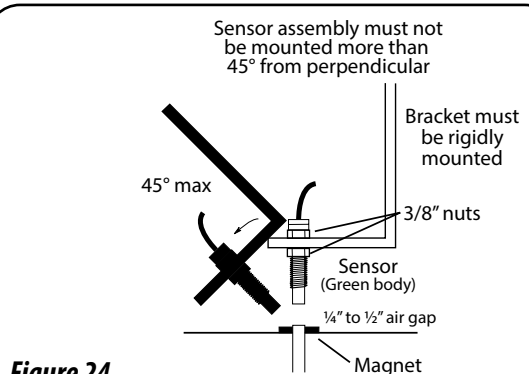

Figure 24

Appendix B- Magnetic Speed Sensor Installation (cont.)

Wheel Mounting

Implement Wheels

1. Secure magnets mechanically or with epoxy.
2. Rigidly mount sensor mounting bracket to the wheel assembly. Cut or bend "L" bracket as required for proper positioning of sensor.
3. Install sensor, adjust to correct spacing ($\frac{1}{4}$ " to $\frac{1}{2}$ " or 6 to 13 mm is recommended), and secure with $\frac{3}{8}$ " locking nuts. See Figure 25.

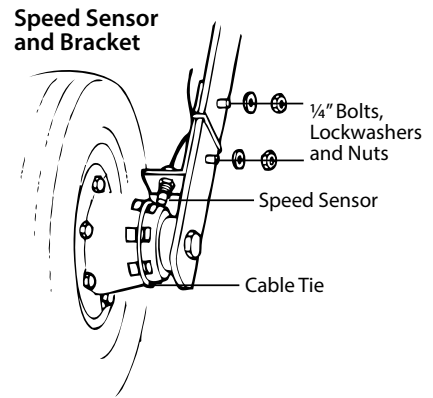

Figure 25

Front Tractor Wheel

1. Magnets may also be secured with a cable tie and an adhesive such as epoxy.
2. Mount the speed sensor bracket to a part of the wheel assembly that does not change position to the hub when the wheels are turned. If the "L" bracket provided cannot be bent and mounted to properly position the sensor, make a bracket similar to the one shown at right.
3. Install sensor, adjust to correct spacing ($\frac{1}{4}$ " to $\frac{1}{2}$ " or 6 to 13 mm is recommended), and secure with $\frac{3}{8}$ " locking nuts. See Figure below.

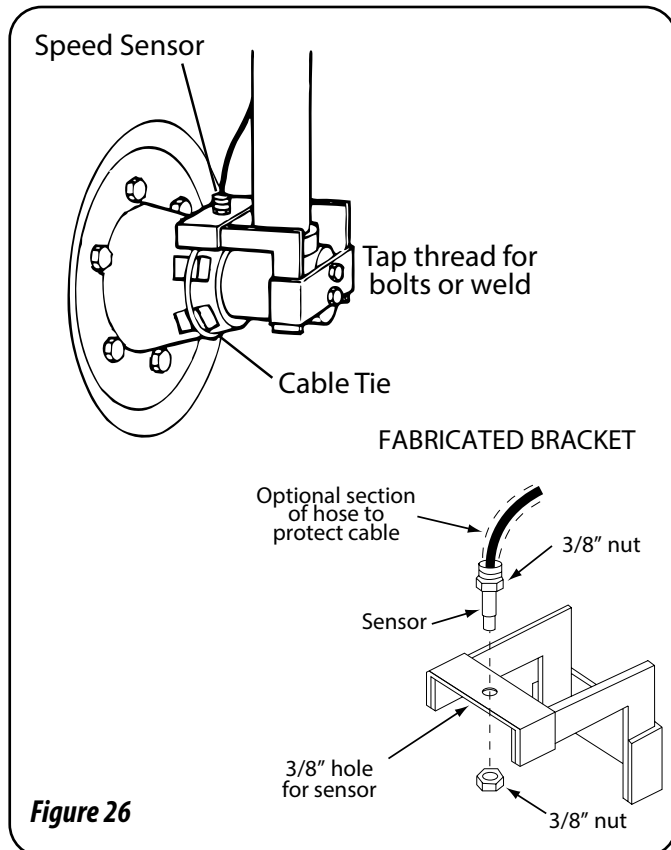

Figure 26

ATV Wheels

1. Using one cable tie (ribbed side toward magnets), secure two magnets to the wheel hub so they are exactly opposite each other. Alternate the magnets' polarities.
2. Cut and bend sensor mounting bracket as needed and rigidly mount.
3. Insert sensor, adjust spacing ($\frac{1}{4}$ " to $\frac{1}{2}$ " or 6 to 13 mm) and secure with $\frac{3}{8}$ " locking nuts.

CAUTION: Make sure valve stem cannot make contact with sensor or bracket.

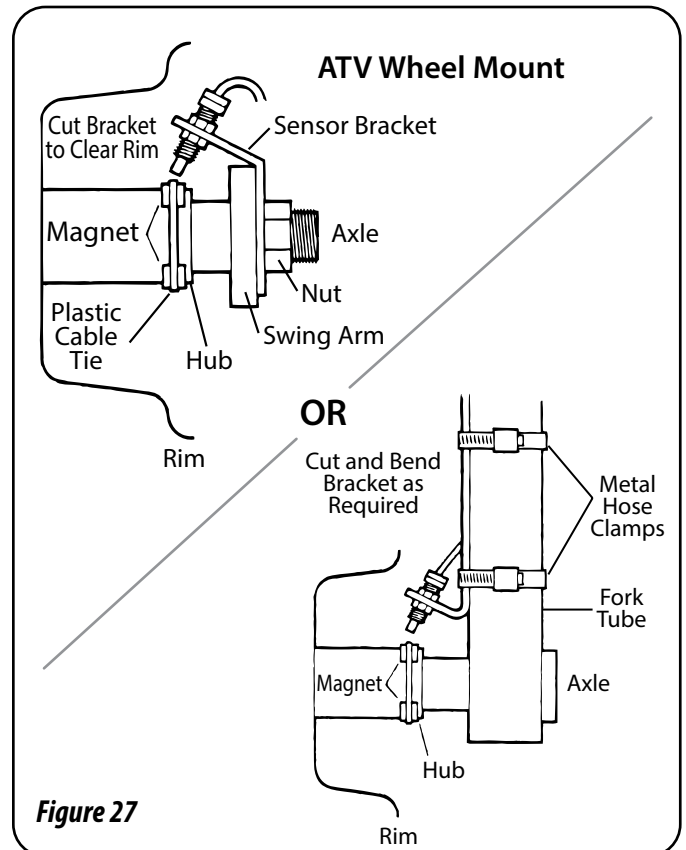

Figure 27

Appendix B - Magnetic Speed Sensor Installation

Wheel Mounted Calibration

To calculate speed and distance accurately, the circumference of the sensor-equipped wheel must be precisely measured.

1. Mark the tire with chalk and measure the distance traveled in one complete revolution (in field conditions).
2. Repeat Step 1 several times - average the results and round to nearest tenth.
3. Divide this number by the number of magnets installed. This is your Speed Cal number.

For maximum accuracy, use the Fine Tuning Speed/Distance Calibration Value procedure on page 43.

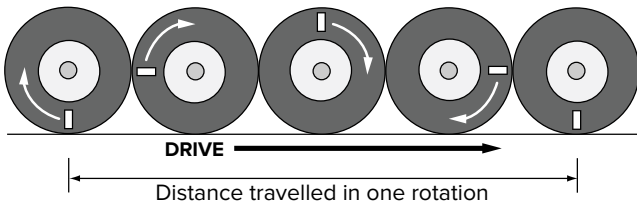

Figure 28

Drive Shaft Mounting

NOTE: This is an optional method generally used on pickups, custom vehicles, or when access to wheels is limited. This installation requires a fine tuning procedure, see page 43.

Determine the best location for the magnets on drive shaft according to which is the most practical spot to attach sensor mounting bracket. See figure 29. This position should be no more than 12" (.30 meters) behind the front U-joint. For best results, mount "L" bracket to transmission and mount magnets on drive shaft as close to transmission as possible. This will ensure proper alignment if drive train shifts under heavy loading.

Two magnets are required for proper Hall-effect speed sensor operation. Position them exactly opposite each other (180 degrees apart). The polarity (north and south poles) detected by the Hall-effect speed sensor must alternate as the shaft is turned. The magnets provided by Micro-Trak® are marked with a punched dashed line on the SOUTH pole side of the magnet.

- Attach magnets onto drive shaft, one NORTH pole side out and the other SOUTH (dashed) pole side out, by wrapping cable tie around shaft and magnets. Position each magnet so that its longest dimension moves in the direction of rotation. Pull cable tie tight and trim off excess. An adjustable, non-magnetic (stainless steel) band clamp may also be substituted.
- Attach sensor bracket to vehicle transmission. See Figure 29 below. Use either the short or long end of the bracket as a base.
- Turn one locking nut onto threaded sensor and insert sensor into large hole selected on mounting bracket. Turn on remaining locking nut. Set sensor to proper distance from magnets (1/4" to 1/2", or 6mm to 13mm). When distance is set, tighten nuts to lock sensor in place.
- Secure sensor cable to frame with cable ties. Place first tie as close to sensor assembly as possible.

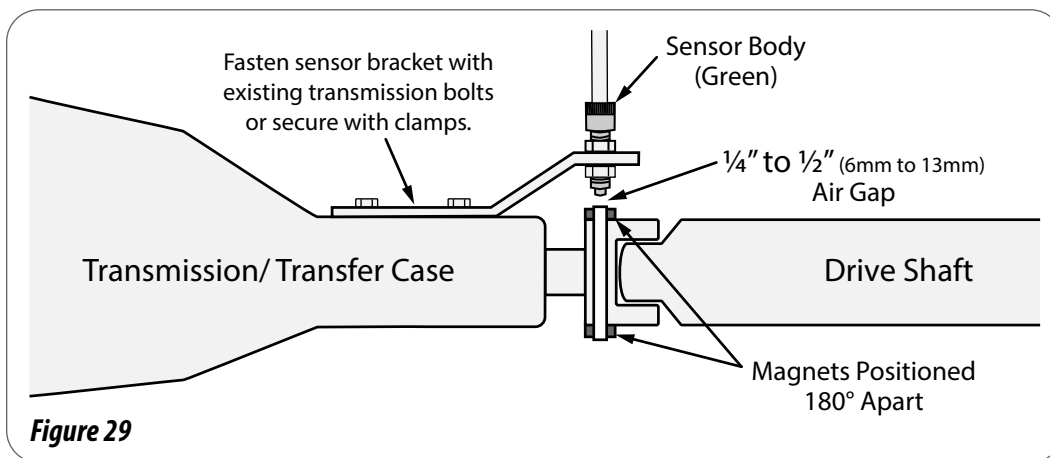

Figure 29

Drive Shaft Mounted Calibration

Because of the variety of wheel-to-drive shaft ratios, it is imprecise to calculate a calibration value by measuring the circumference of a wheel. Use the Fine Tuning Speed/Distance Calibration Value procedure on page 43 to calibrate.

Appendix C - Fine Tuning Speed/Distance Calibration Value

This procedure is used to verify the Speed/Distance calibration. In order to achieve accurate measurements, each step in this fine tuning procedure should be performed as precisely as possible.

PREPARATION

- Once the system is fully installed and calibrated, select a straight tract of ground that is similar to your actual application conditions and as level as possible.

NOTE: Using a course with a different ground surface, such as a hard-surface road, will result in different readings than exact application conditions.

- Accurately measure a distance of 1000 feet (300 meters). Clearly mark the beginning and end points with flags or something highly visible to the operator.

PROCEDURE

1. With the console turned ON, place the Run/Hold switch in the HOLD position. (the HOLD icon will be displayed). Turn the rotary dial to the DISTANCE position. Reset the distance counter by pressing and holding "RESET" until the display returns to 0. (CLEAR will be displayed when reset is pressed). Make sure pump is off. Turn on the section switches.
2. You are now ready to drive the measured course. Pick a location on the vehicle to use as a marker for starting and stopping the distance counting function (door handle, mirror, step, etc.). You should begin driving the course well ahead of the starting flag and drive past the ending flag, using the Run/Hold switch to start and stop the counting function. It is not recommended to start from a dead stop at the starting flag and stop at the ending flag.
3. Place the Run/Hold switch in RUN when the marker on the vehicle passes the starting flag to activate the distance counting function. The console display numbers will increase, adding to the distance total as you drive. Drive the pre-measured course and place the Run/Hold switch in HOLD, when the marker on the vehicle passes the ending flag, to stop the distance counting function. The console display should display "HOLD". Stop the vehicle in a level and safe area and continue with this procedure.

4. With the rotary dial still at DISTANCE (SPEED CAL), press and hold the CAL button for one second. Once the console is in "CAL," the speed calibration value will be displayed. Momentarily press the CAL button and the word "CAL" will begin to flash and the distance travelled will be displayed. *See figure 30 below.*



Figure 30

5. When the display shows distance ("CAL" is flashing), verify whether the number displayed is the exact distance you drove (+/- 1 - 2 %). If not, press the **Increase** or **Decrease** button to adjust the figure to match the distance driven.
6. When the number shown on the display matches (as closely as possible) the actual distance driven, you have arrived at the correct calibration value. If you cannot adjust the displayed distance to exactly match the actual distance driven, adjust the figure as close as possible to the actual distance. You may check the calibration number by momentarily pressing the CAL button. The word "CAL" will stop flashing and the SPEED CAL number will appear. Exit "CAL" by pressing the CAL button for one second.

The speed sensor is now calibrated. To verify proper calibration, repeat the procedure a second time. Write down the new speed calibration number and keep it in a safe place. If the calibration values are ever accidentally changed, you can simply re-enter this number.

Appendix D - Fine Tuning Flowmeter Calibration Value

This procedure is used to verify and fine-tune the flowmeter calibration. Every flowmeter is calibrated with water at the factory and stamped with a calibration value. Enter that value as a starting point and use this procedure to fine-tune that value for your specific installation and spraying application. This procedure should be repeated each time a new solution is being applied or when the flowmeter installation has been altered. (*Differing solutions have different specific gravities and flow characteristics.*)

PROCEDURE

1. Fill sprayer tank with water - preferably 100 gallons or more. The larger the volume of water used, the more accurate the calibration.)
2. Start sprayer pump and turn on sections until air is purged from lines. Turn off sections but leave pump running.
3. Turn on MANUAL mode. Then switch to RUN.
4. Turn rotary knob to VOLUME/MINUTE. Adjust rate to amount needed for target rate using Increase/Decrease buttons.
Gallons per Acre X MPH X Width in feet ÷ 495=Gallons per Minute
5. Switch to HOLD.
6. Turn console rotary knob to the VOLUME position. Select the counter (1-3) that you want to use. Press and hold the RESET button until the display reads 0 (1 second).
7. Turn on all sections, turn Run/Hold switch to RUN, and run a known amount a water (preferably 100 gallons or more). *
8. Put Run/Hold switch in HOLD position. Compare the console's VOLUME reading with the known amount of water run. If the two amounts are within two percent, no fine tuning is required. If the two amounts are more than three percent different, continue with the next step.

9. With the console still in the VOLUME position, enter calibration, hold the CAL button until the red warning light comes on (about one second). The display will show the flowmeter calibration value and the CAL icon.
10. Momentarily press the CAL button, The CAL icon will begin the flash and the total volume will be displayed. *See figure 31 below.*
11. When the TOTAL FLOW value is displayed, use the **Increase or Decrease** button to adjust the value to match the amount of water run.
12. Momentarily press the CAL button. The CAL icon and the flowmeter calibration number will be displayed. You will notice that the flowmeter calibration value has changed. Write down the new flowmeter calibration value. This is your "fine tuned" calibration number, keep it for future reference.
13. Exit calibration by holding the "CAL" button until the red warning light goes out (about one second).

* **The most accurate method to measure the volume of water run is to place a container under EVERY nozzle and add together the amount from each nozzle. This assures that 100 percent of the water is collected and that all nozzles are spraying equally. It is important to perform this procedure at a flow rate similar to that which will be used in the field. It is also possible to disconnect the main boom line and run it to a large measuring container but a valve must be installed and properly adjusted to simulate actual field conditions.**



Figure 31

Appendix E - “Quick Start” Function

There are two different Quick Start methods, “**Quick Start - SPEED**” and “**Quick Start - VALVE**”, which can be enabled for use in Automatic operating mode. Each method uses a separate set of Special Calibrate parameters, and only one method can be enabled at a time (the other must be disabled). See Special Calibration section to enable/adjust the parameters.

Quick Start - SPEED

Provides an instant Speed (simulated) whenever the system goes from HOLD to RUN.

USAGE:

This is useful for applications where the delay associated with acquiring enough Speed signal pulses to provide the console with a valid operating speed is unacceptable. This is intended for situations where the application equipment is quickly going from a stopped condition (Speed=0) to an operating speed.

SETUP:

Two Special Cal factors, **START SPEED** and **START SPEED TIME**, must be set (values > 0) to enable this feature.

* **Important:** Verify that “Quick Start -VALVE” is disabled: (START TIME = ‘OFF’).

* **Important:** Make sure AUTO DELAY TIME = 0, so it does not add any delay to the Quick Start feature.

HOW IT WORKS:

When switching from HOLD to RUN, the console will use the **START SPEED** value as the simulated Speed (example: 5 mph) for **START SPEED TIME** (example: 2 seconds).

Quick Start - VALVE

Provides a “jump start” to open the control valve by running it immediately after some movement is detected.

USAGE:

On some Standard DC servo and all PWM systems, the control valve is used to completely stop the hydraulic flow when in HOLD (see ***Note** below). In those systems there may be an undesirable delay for the Servo or PWM valve (which may “stick” off) to return to normal operating flow again. “Quick Start -VALVE” can be used to reduce this delay by “jump starting” the hydraulic flow to allow AUTO control to reach the Target Application Rate faster, resulting in a smaller area of under application. The optimal settings for **START TIME** and **START PERCENTAGE** will require experimentation. If the values are too small there will be little improvement in startup time, and if too large it will overshoot the desired application rate.

***Note:** A HOLD condition can be generated by: Run/Hold switch (or sensor) in HOLD position, or when all non-zero width sections are switched OFF, or if ground speed is 0 in AUTO (automatic All-Sections-Off feature).

SETUP:

Depending on the type valve used, certain Special Calibrate factors must be set up as indicated below.

- Standard servo valve:
 - Only one Special Calibrate factor, **START TIME**, must be set (value > 0) to enable this feature.
- PWM valve:
 - Two Special Calibrate factors, **START TIME** and **START PERCENTAGE**, must be set (values > 0) to enable this feature.

* **Important:** Verify that “Quick Start -SPEED” is disabled: (START SPEED = ‘OFF’ and START SPEED TIME = ‘OFF’).

* **Important:** Make sure AUTO DELAY TIME = 0, so it does not add any delay to the Quick Start feature.

HOW IT WORKS:

After a change from HOLD to RUN and after the vehicle has traveled about 10 inches:

- Standard servo valve:
 - The servo control valve (previously closed) is run towards open for **START TIME** (example: 1 second).
- PWM valve:
 - The PWM valve is “cracked” open by running it at specific duty cycle above **MIN PW** determined using **START PERCENTAGE**, for a short time interval specified by **START TIME**.

Appendix F - NH3 Control

Wiring Connections for NH3

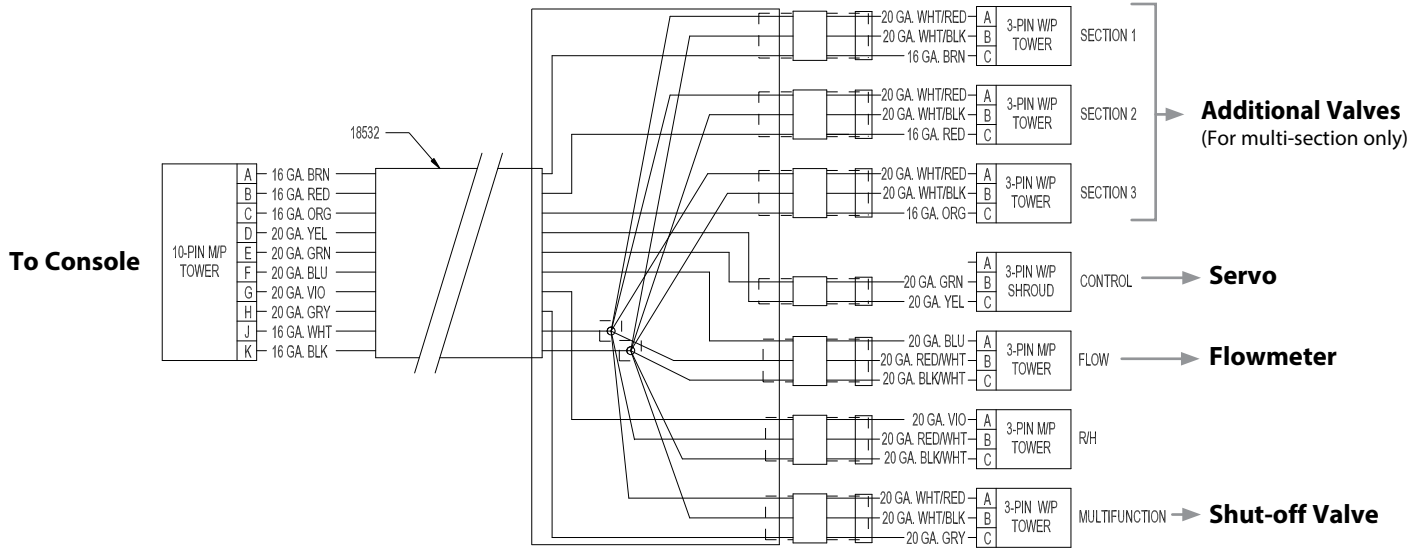

Appendix F - NH3 Control

Typical Installation for NH3

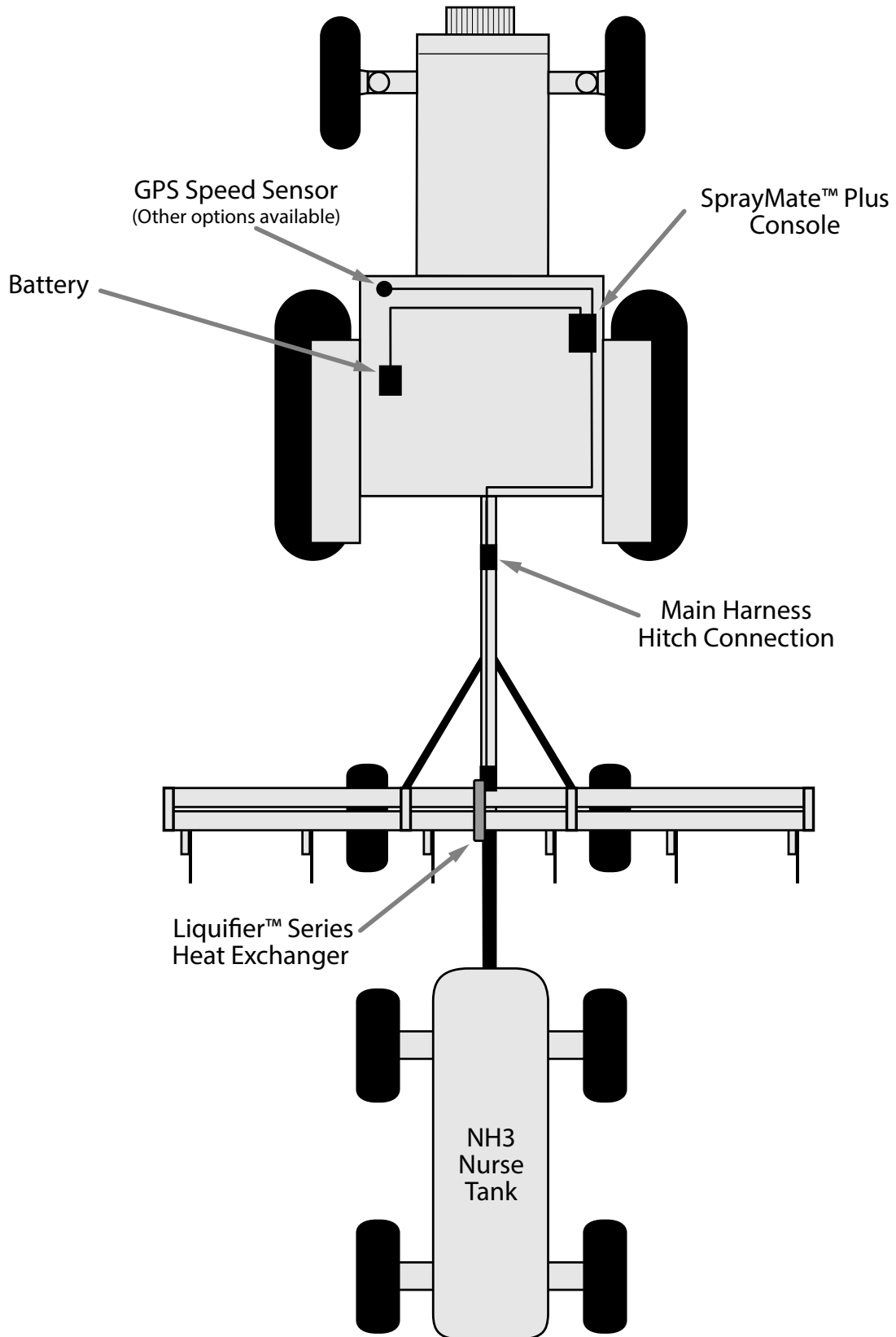

Appendix F - NH3 Control

Connection to Liquifier™ NH3 Kits

Branch Harness

An NH3 system can be connected to SprayMate™ Plus using the Branch Harness, P/N 18532, shown here. Choose an appropriate length extension cable (for example, P/N 14316 shown below). *See Appendix M for various extension lengths.*

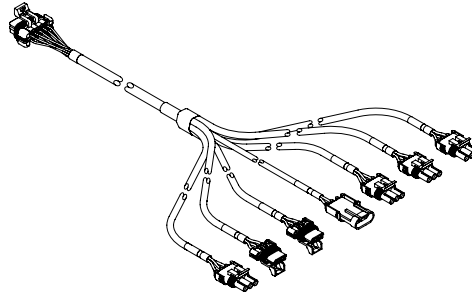

Branch Harness
w/Weather Pack Tower Conn.
P/N 18532

Extension Cables

A 10-pin extension cable will be needed to join the Console and harness wiring together. *See Appendix M for various extension lengths.*

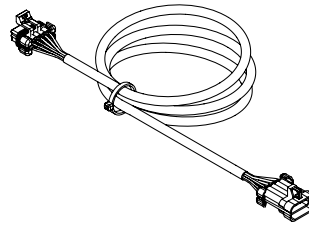

120" 10-pin Extension Cable
P/N 14316

Liquifier™ Series Heat Exchangers



Liquifier™ Ultra Low Rate Kit
P/N 01815

2800 lbs. NH3/hr.
11 GPM(@100 PSI)



Liquifier™ Kit
P/N 01817

12000 lbs. NH3/hr.
40 GPM(@100 PSI)



Liquifier™ Junior Kit
P/N 01816

6000 lbs. NH3/hr.
23 GPM(@100 PSI)



Liquifier™ MAX Kit
P/N 01818

21000 lbs. NH3/hr.
70 GPM(@100 PSI)

Liquifier Installation

LIQUIFIER KIT INSTALLATION

Remove any existing metering valves. If the old metering valve has a built-in manifold, it is recommended to install a separate new manifold for the Liquifier™ kit. Another option, although not recommended, is to use the existing manifold, making certain the old metering valve is in the maximum open position to allow for minimal restriction of flow through the plumbing. There should not be any positive shut-off valves installed in the plumbing between the Liquifier kit shut-off valve and the knives.

Install the plumbing panel on the tool bar frame using the carriage bolts and flange lock nuts through the top and bottom brackets of the system. Trim any excess length off the bolts if required. Attach the hose from the breakaway coupler to the strainer inlet. Check for proper hose length for operation of the disconnect mechanism of the breakaway coupler. Connect the manifold hose to the servo valve outlet. Check for proper hose length to avoid kinking at the hinge points.

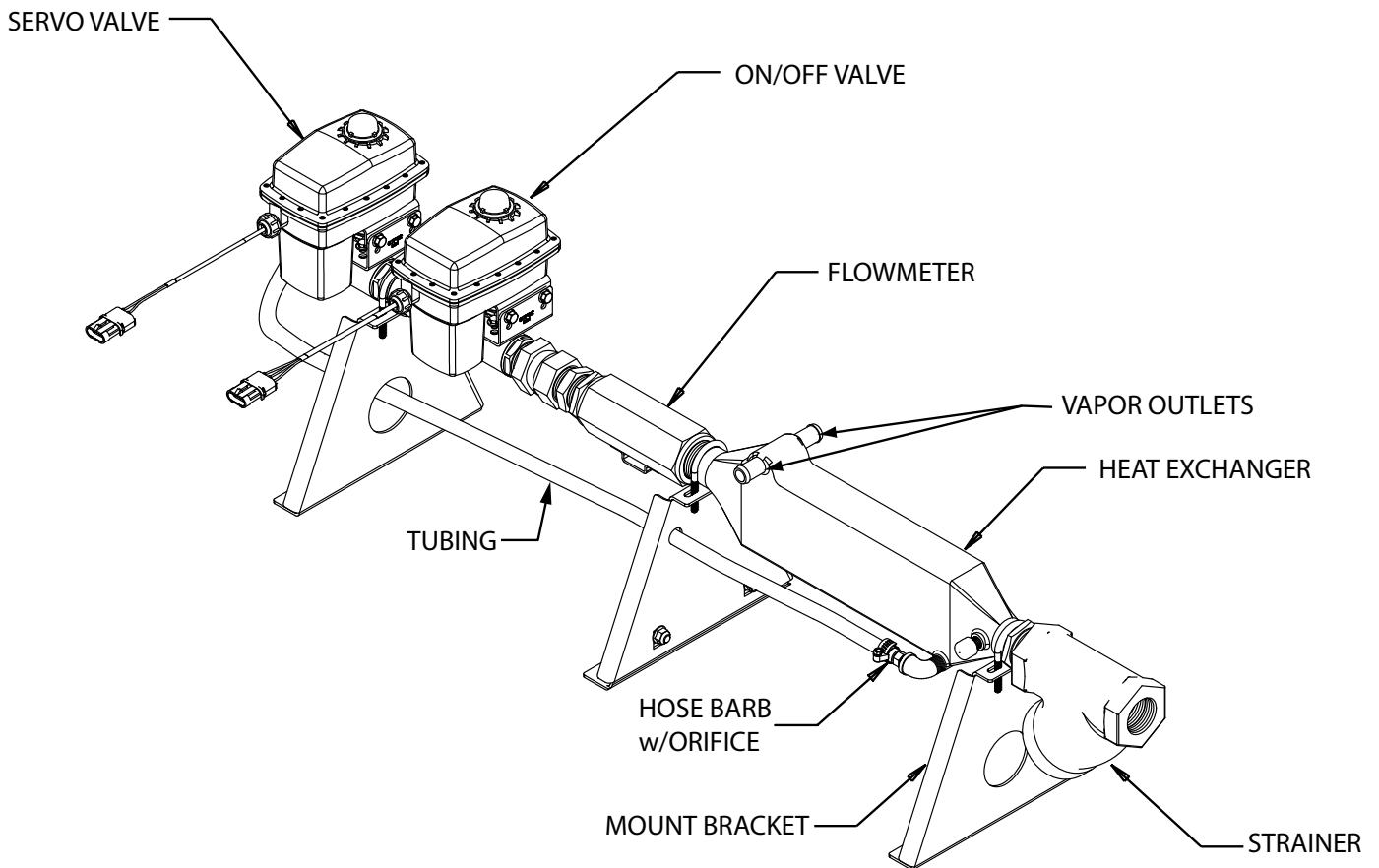

INSTALLATION NOTE: It is recommended to use an NH3 compatible thread sealing compound on all pipe thread fittings.

Appendix F - NH3 Control

Liquifier™ Series - Vapor Line Installation

Locate the 1/2" EVA vapor hose supplied with the kit. Starting on one half of the tool bar, connect the 1/2" hose to the outside steel vapor tube. Route the hose up the shank and along the tool bar frame to the inside steel vapor tube. Allow enough extra hose to avoid kinking at hinge points. Cut the hose to length and attach to the inside steel vapor tube. Install a 1/2" x 3/4" x 1/2" tee fitting approximately halfway along this hose between the outside and inside steel vapor tubes. *See Illustration below.* Repeat the same procedure for the steel vapor tubes on the other half of the tool bar. Secure all hoses with properly sized hose clamps. Secure the hoses to the tool bar frame with cable ties.

Locate the 3/4" EVA hose supplied with the kit. Connect to one of the 1/2" x 3/4" x 1/2" tee fittings and route along the tool bar frame to other 1/2" x 3/4" x 1/2" tee fitting. Cut to length and install on the tee fitting. Allow enough extra hose to avoid kinking at hinge points. Now install a 3/4" x 3/4" x 3/4" tee fitting approximately halfway along this hose (center of the tool bar) between the other two tee fittings. Using an appropriate length 3/4" hose, connect this tee fitting to the vapor tube connection on the Liquifier™ plumbing panel. Secure all hoses with properly sized hose clamps. Secure the hoses to the tool bar frame with cable ties.

FOR ALL NH3 KITS

Weld the steel vapor tubes to the back of your liquid tubes. All electronic equipment, including the console and radar speed sensor, **MUST BE DISCONNECTED BEFORE WELDING ON EQUIPMENT.** The four steel vapor tubes should be evenly spaced across the applicator (two per side) and installed so that only their wear resistant surface contacts the soil. Mount the tubes just high enough to avoid plugging.

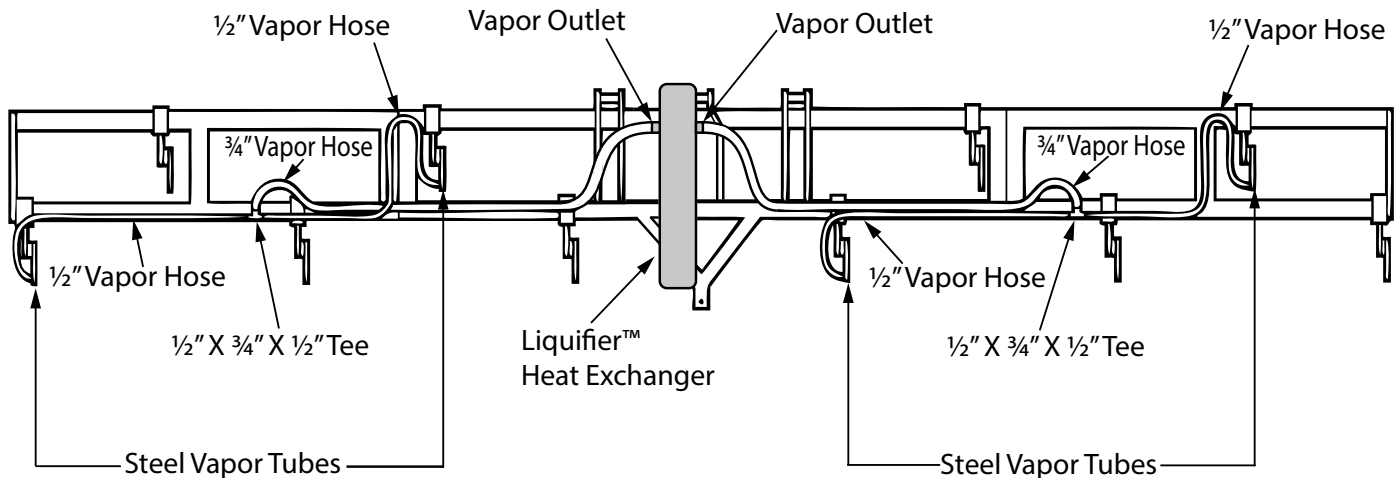
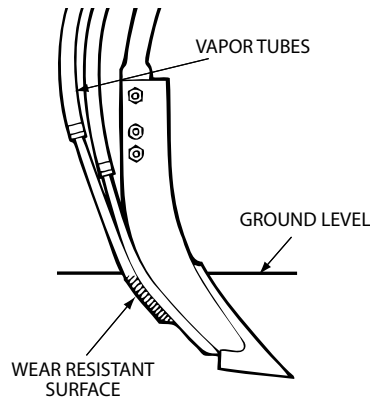

Electrical Connections

The main wiring harness connections are the same for both liquid and NH3. The harness combines the wires for the servo valve, flowmeter, and on/off valve.

PROCEDURE TO CONNECT HARNESS TO LIQUIFIER™:

1. Join the FLOW connection to the flowmeter.
2. Join the CONTROL connection to the Servo Valve.
3. Join the MULTIFUNCTION connection to the On/Off valve.
4. Connect the harness to the SprayMate™ Plus console using the 10-pin extension cable - P/N 14316.

Appendix F - NH3 Control

Console Setup & Calibration for NH3 Application

To begin setup the SprayMate™ Plus console for NH3 application, first enter Special Calibration mode:

1. Turn the console OFF.
2. For safety, place system in HOLD via the RUN/HOLD switch.
3. Press and hold the Calibration Button and turn the console ON.
4. Release the Calibration Button. The Data Window will display "SPEC" to show that Special Calibration mode is active. Calibration LED below the rotary dial will also be lit.

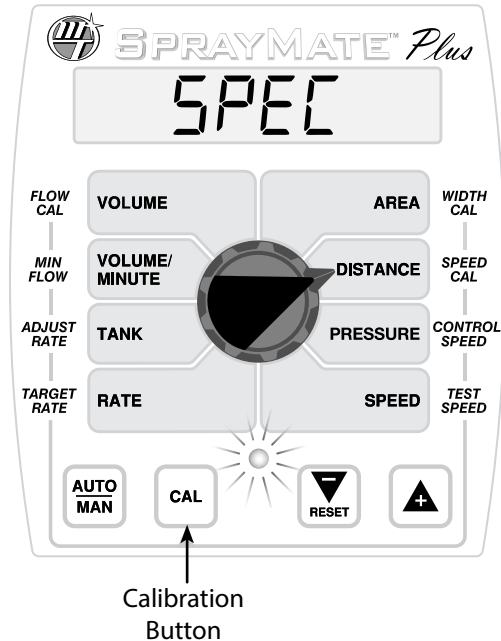

5. Turn the rotary dial to the Distance position to enter Special Calibration - Material. The default shown in the Data Window is H2O, press the square Increase (+) button to choose NH3 as material for application (see below). (To review other Special Calibration parameters, see page 23.)
6. Save this change and exit Special Calibration by pressing the Calibration Button for 1 second.

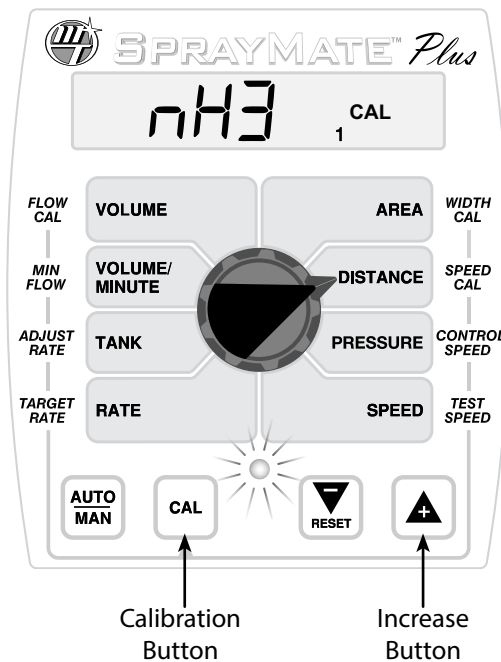

Appendix F - NH3 Control

Console Setup & Calibration for NH3 Application

NH3 mode rates and totals in lbs. (kg) of nitrogen (N) or anhydrous ammonia (NH3) as shown below.

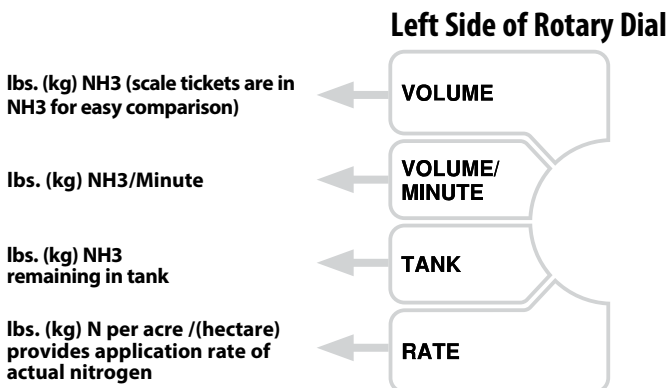

To continue preparing the console for NH3 application, enter (standard) Calibration mode:

1. Press the Calibration Button and hold until Calibration LED is lit.
2. Adjust values for Flow Cal, Minimum Flow, Adjust Rate, Target Rate, Width Cal, Speed Cal, and Control Speed. These positions are marked on the perimeter of the rotary dial area.
3. Save changes and exit Calibration by pressing the Calibration Button for 1 second.

FLOW CAL

This position is used to calibrate the system to the flowmeter for accurate NH3 measurement. The flowmeter has been calibrated at the factory. Enter the "Micro-Trak NH3 cal" number found on the plastic tag attached to the flowmeter. *See example below.* The Cal number is a starting point only and must be fine tuned. **See Fine-Tuning Flowmeter Calibration for NH3 on page 54.**

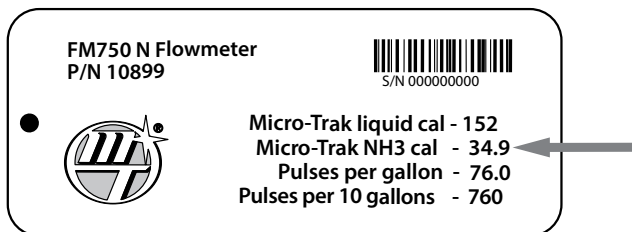

MIN FLOW

Enter a minimum flow rate of 10.0 lbs. per minute (5.0 kg per minute) of NH3. This will prevent the system from applying below the recommended minimum rate for the Micro-Trak NH3 flowmeter.

Note: If applying NH3 using multi-section control, leave Min Flow value at 0. Then, enter Special Calibration mode (see pg. 23 for instructions) and navigate to **Fixed Minimum Flow** feature. Enter a minimum flow rate of 10.0 lbs. per minute (5.0 kg per minute) of NH3. Exit Special Calibration mode.

This setting will prevent the system from applying below the recommended minimum rate for the Micro-Trak NH3 flowmeter, including if one or more sections is turned off.

ADJUST RATE

Enter the desired amount of change in pounds (kg) of actual "N" applied per acre (hectare) for on-the-go adjustments to the Target Rate when operating in AUTO mode. Enter 0 to disable this feature.

TARGET RATE

Adjust the value for the desired target application rate of lbs. of N per acre (kgs of N per hectare). This is the application rate that the console will lock onto when operating in AUTO.

Appendix F - NH3 Control

Console Setup & Calibration for NH3 Application

WIDTH CAL

Use the Increase/Decrease switches to adjust the number to the working width of your tool bar in inches (thousandths of meters). The “working” width is the width of ground being affected by any operation - for NH3, this equals the number of knives times the spacing. For example, if you have **8** knives spaced at **30** inches, the working width is **240** inches. For multi-section setup, quickly press and release the CAL key until the desired Section Number is on, then adjust the value.

SPEED CAL

This position is used to calibrate the system to the speed sensor for accurate speed and distance measurement. When this position is selected, the display will show the SPEED CAL value along with “CAL” on the display. *See Speed Calibration section (page 22) for details.* To fine-tune the SPEED CAL, see Appendix C Fine Tuning SPEED CAL page 43.

CONTROL SPEED

(OPTIONAL) This position adjusts valve response time to fine-tune the system. Example: increase Control Speed if the system is responding slowly to rate changes because of slow-moving valves. The default setting is -1 and range is -12 to 3.

NOTE: Exercise caution when increasing the valve response speed - the system may become unstable with higher control speed numbers entered.

REMINDER: To save any changes to calibration values, you **MUST** exit calibration by pressing and holding the CAL button until the CAL icon disappears and the Calibration LED turns off.

NOTE: TEST SPEED is not used during NH3 setup.

Appendix F - NH₃ Control

Fine Tuning Flow Calibration Value - NH₃ Systems

This procedure is used to verify and fine-tune the flowmeter calibration. Every flowmeter is calibrated with water at the factory and stamped with a calibration value. Enter that value as a starting point and use this procedure to fine-tune that value for your specific installation and NH₃ application (**Please refer to Flow Cal page 52**).

PROCEDURE

1. Start with a full nurse tank. Make certain that you have an accurate scaled weight of the full tank. Plan to apply a minimum of 1,000 pounds of NH₃ for this procedure. The larger the volume of NH₃ used, the more accurate the calibration will be.
2. Place system in HOLD via the RUN/HOLD switch. Turn the rotary selector to the VOLUME position. Select a counter (1-3) using the Increase (+) button. Press and hold the RESET(-) button until the display reads ".0".
3. Proceed to the field and perform actual application until at least 1,000 pounds of NH₃ has been applied. (One nurse tank is preferred.) To apply, switch section(s) on and place system in RUN via the RUN/HOLD switch.

After application, accurately weigh the partially used tank. The difference between the starting and ending weight is your calibration weight.
4. Compare the console's VOLUME reading with the known amount of NH₃ run. If the two amounts are within one or two percent, no fine tuning is required. If the two amounts are more than two or three percent different, continue with the next step.
5. With the console still in the VOLUME position, enter calibration, hold the CAL button until red warning light comes on; about one second. The display will show the flowmeter calibration value and the CAL icon.
6. Momentarily press the CAL button. The CAL icon will begin to flash and the total volume will be displayed.
7. When the TOTAL FLOW value is displayed, use the square "+" or "-" button to adjust the value to match the amount of NH₃ run.
8. Momentarily press the CAL button. The CAL icon and the flowmeter calibration number will be displayed. You will notice that the flowmeter calibration value has changed. ***Write down the new flowmeter calibration value. This is your "fine tuned" calibration value, keep it for future reference.***
9. Exit calibration by holding the "CAL" button until the red warning light goes out (about one second).

Appendix F - NH3 Control

Field Operation - Troubleshooting for NH3

Always follow accepted safety precautions. Make sure that equipment is in good operating order. Before connecting the nurse tank to the applicator, check the electric shut-off valve of the SprayMate™ Plus system for proper operation.

After changing nurse tanks or after other periods of long shut-down, operate the system in MANUAL until the application rate stabilizes. This allows the heat exchanger to reach operating temperature before selecting AUTO. Erratic operation may be experienced if AUTO is selected before operating temperature is reached.

The Liquifier™ system uses NH3 vapor to cool the heat exchanger, changing the mix of gas and liquid entering the system into 100% liquid before it enters the flowmeter. A small percentage of liquid NH3 is tapped off between the shutoff valve and control valve and enters the vapor side of the heat exchanger. As it enters the heat exchanger, it passes through a hose barb equipped with a 3/32" orifice. This regulates the amount of NH3 that passes through the exchanger as a coolant. As it passes through the orifice, the pressure release converts the liquid NH3 to vapor. This change causes the vapor to drop to a very low temperature which allows it to be used as a refrigerant, turning the incoming NH3 to 100% liquid.

Erratic application rate

1. Start applying and when your rate is close to your target, select the gallons per minute, or lbs per minute display on your controller. This is the reading directly off the flowmeter. Place the controller in MANUAL. This stops movement of the control valve. If the rate stabilizes the erratic operation is most likely induced by the control system.

Possible Solutions:

- A. Set the VALVE CONTROL SPEED to a lower setting. Negative values slow down the response of the valve, positive numbers make the response more aggressive. Typical control speed values for NH3 application are -2 to -4, but vary by installation.
- B. Verify adequate manifold pressure. Manifold pressure is very important for smooth control and even distribution of NH3. Use barbed fittings with properly sized orifices or an adjustable manifold to maintain adequate pressure. If manifold back pressure is too low, the only resistance to the flow of NH3 is the control valve. At lower rates, this will result in the control valve operating almost fully closed. This results in erratic control since the flow through the valve can vary greatly with minimal movement. Adequate back pressure allows the valve to operate in a more open position which results in stable application rates. Typical manifold pressure ranges from 15 to 60 PSI (1 to 4 bar) depending on application rates and ambient temperature.

2. If the rate continues to bounce around while in MANUAL, vapor may be entering the flowmeter. Any obstruction (clogged filter, partially closed tank valve, plugged tank dip tube) can cause a pressure drop which will in turn generate large amounts of vapor.

Possible Solutions:

- A. If the rate in MANUAL is varying by a small amount (10 - 20 lbs per acre) this may indicate worn bearings in the flowmeter.
- B. Verify the vapor line and vapor control orifice are clean and free of obstruction.
- C. Verify the strainer is clean.

Poor System Performance

In NH3 control systems, location of the frost build-up is an indication of system performance. The NH3 kit will normally have frost on the output side of the servo valve and on the bottom portion of the heat exchanger. Frost before the servo valve or on the flowmeter indicates vapor in the system as a result of excessive pressure drop (caused by obstructions) in the delivery system, restricted vapor lines or clogged vapor control orifice.

The strainer is a common source of excessive pressure drop and should be cleaned regularly. AFTER COMPLETELY DRAINING THE SYSTEM, remove the large plug and carefully clean the strainer screen. Also, periodically check the vapor tubes for obstructions.

Appendix F - NH3 Control

Flowmeter Assembly (FM-750 N)

IMPORTANT: Opening the flowmeter will void the Flow Calibration value assigned to your unit. However, you may need to take the flowmeter apart for periodic cleaning or to remove an obstruction. *See illustration below for flowmeter reassembly instructions.*

TO OPEN THE FLOWMETER

Disconnect the hose from servo valve to manifold. Loosen the union hex closest to the heat exchanger. Remove the two "U" bolts that hold the servo/flowmeter assembly to the brackets. Unscrew the union from the heat exchanger and remove the servo/flowmeter assembly.

Use running water to rinse the assembly of any accumulated dirt. Remove the three flowmeter bolts, carefully open the flowmeter and remove the turbine. Thoroughly clean turbine and housings of any foreign material (dirt, pieces of teflon tape, rust on magnets, etc.).

Set and spin the turbine in each flowmeter housing half. It should spin freely. If not, remove the turbine, wipe the shaft and try again.

TO ASSEMBLE THE FLOWMETER

Place the servo, flowmeter end up, in a vice or other suitable fixture. Set turbine in non-sensor housing. Properly position gasket on housing. (**Gasket may be reused a few times but will eventually need to be replaced.**) Pipe thread compound is not absolutely necessary but will insure a good seal. Be careful not to get compound inside flowmeter or turbine will stall. Carefully put other flowmeter housing (sensor half) in place. (**Position the housing so that the two square lugs are lined up with each other.**) Drop all three bolts into holes. Hold lock washers in place and finger tighten all three nuts. Nuts should be torqued to 120 in./lb. (13.56 nw/m). Attach tag by running wire between a bolt and the housings, and twisting.

After assembly, shaking flowmeter end-to-end should produce a "rattling" sound (shaft end play). Blowing into the meter from either end should cause the turbine to spin freely. If the turbine only spins from one direction, install the flowmeter so that the liquid flows in that direction.

NOTE: Start with original calibration number and follow fine tuning for verifying flowmeter accuracy.

Warning

TO PREVENT SERIOUS INJURY, DO THE FOLLOWING:

1. **ALWAYS WEAR** gloves, goggles, and other necessary equipment when handling NH3 apparatus.
2. **DO NOT** cross thread. Use anti-seize lead base thread compound.
3. **THOROUGHLY BLEED** hoses before disconnecting NH3 apparatus.
4. **COMPLETELY EVACUATE** NH3 apparatus before servicing.

Complete Assembly
FM750 N Flowmeter
P/N 10899

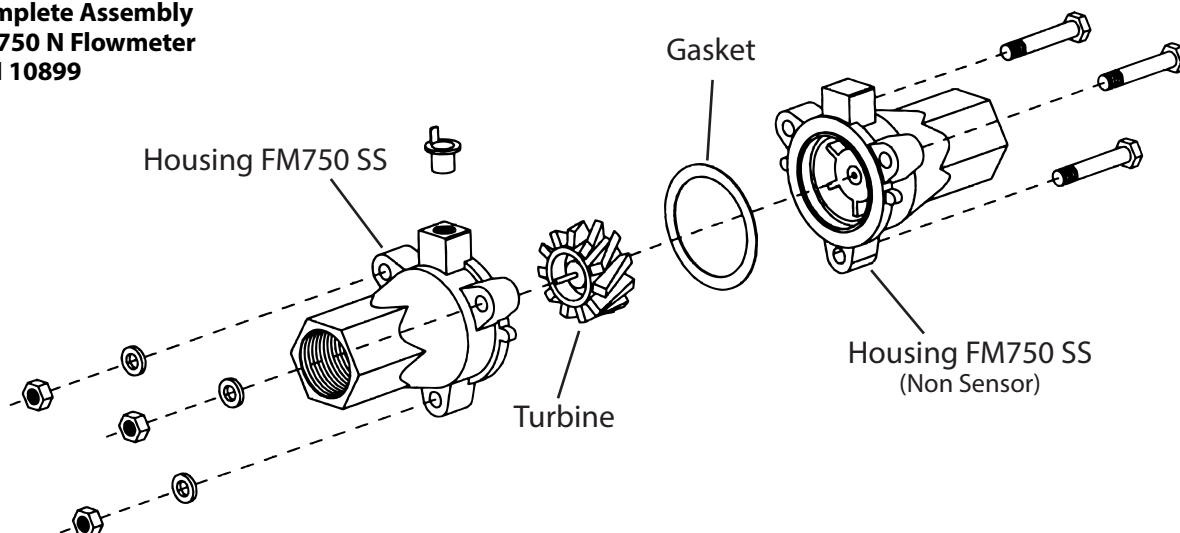

Appendix F - NH3 Control

Flowmeter Assembly (FM-1500 N)

IMPORTANT: Opening the flowmeter will void the Flow Calibration value assigned to your unit. However, you may need to take the flowmeter apart for periodic cleaning or to remove an obstruction. *See Illustration below for flowmeter reassembly instructions.*

TO REMOVE THE FLOWMETER

Loosen two 1/2" bolts securing unit (shutoff valve end) to tool bar. Loosen union between flowmeter and shutoff valve. Slide shutoff valve away from flowmeter and unscrew flowmeter from heat exchanger.

TO DISASSEMBLE THE FLOWMETER

Remove retainer clip from one end and slide out internals. *See Illustration below.* Be careful not to bend turbine shaft.

Clean and inspect parts.

Assemble in reverse order.

After assembly, shaking flowmeter end-to-end should produce a "rattling" sound (shaft end play). Blowing into the meter from either end should cause the turbine to spin freely. If the turbine only spins from one direction, install the flowmeter so that liquid flows that direction.

If turbine does not spin freely, flowmeter may require repair. Turbines and bearing replacement kits are available.

NOTE: Start with original calibration number and follow procedure in manual for verifying flowmeter accuracy.

Warning

TO PREVENT SERIOUS INJURY, DO THE FOLLOWING:

1. **ALWAYS WEAR** gloves, goggles, and other necessary equipment when handling NH3 apparatus.
2. **DO NOT** cross thread. Use anti-seize lead base thread compound.
3. **THOROUGHLY BLEED** hoses before disconnecting NH3 apparatus.
4. **COMPLETELY EVACUATE** NH3 apparatus before servicing.

Complete Assembly FM1500 N Flowmeter P/N 14348

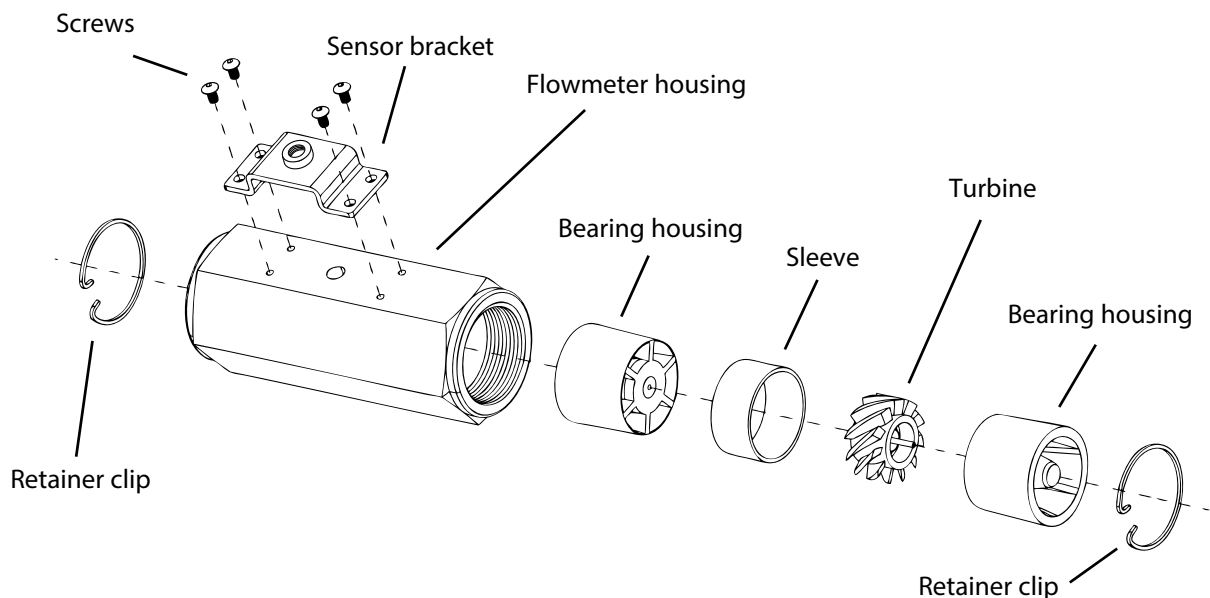

Appendix G - “Open Loop” Control & Closed Loop Override

Note: This feature can only be used with a PWM control valve.

OVERVIEW

Ideally an automatic control system is run using Closed Loop operation which uses feedback from a flow meter (or motor RPM sensor) to adjust the application rate based on ground speed. However, there may be applications in which using a flowmeter is either not possible or not practical. Open Loop control is intended for use in a system that does not use a flowmeter (no feedback). Some possible examples may include:

- Flowmeter cannot provide reliable feedback due to the type of applied product.
- Accurate measurement of flow is not necessary.
- Flowmeter is not desirable (short lifetime due to corrosive material)
- Flowmeter cannot be used (material cannot pass through flowmeter).
- Flowmeter cannot be used because flow-rates are too low for flowmeter to measure.

Closed Loop OVERRIDE is intended for when a flowmeter has broken, but the operator is in a situation where the flowmeter cannot be fixed (replaced) and it is important to finish the job. Activating the Override allows the system to behave as if operating in “Open Loop”. For example, a broken flowmeter (no flow signal) will result in an Emergency Stop condition (control valve and section outputs automatically turned OFF). Pressing the CAL button will clear the \square FLO message and activate Override mode which will stay in effect until power is cycled or Calibrate is entered and exited. **Note:** Override cannot be activated unless the parameters ‘FLOW@MAX PW’ and ‘FLOW@MIN PW’ are correctly set up.

SETUP

Open Loop requires five parameters (located on page 4 of “Special” Calibration) to be set up. Open Loop (CLOSED/OPEN LOOP) uses an estimated flow rate (FLOW@MIN PW and FLOW@MAX PW) based on the PWM duty cycle (MIN PW and MAX PW) to adjust the application rate based on ground speed. In order to use Closed Loop Override, CLOSED/OPEN LOOP is set to “CLOSE” but the other four must be set.

FLOW@MIN PW is the Volume/Minute applied when the PWM control valve is operating at **MIN PW** independent of the number of sections turned on. This value must include all nozzles on the sprayer: Minimum Volume/Minute per Nozzle * Total Number of Nozzles. When some sections are turned off, it is assumed pressure will increase but the flow will remain equal to FLOW@MIN PW due to the positive displacement pump. Similarly, **FLOW@MAX PW** is the Volume/Minute applied when the PWM control valve is operating at **MAX PW** duty cycle. Maximum Volume/Minute per Nozzle * Total Number of Nozzles.

Note: Refer to Special Calibration section for more details. Also, note that “Live Calibration” can be a useful tool to help determine the FLOW@MIN PW and FLOW@MAX PW parameters.

OPERATION

In general the hydraulic valves and motors used in Open Loop are linear through the majority of their range if the system is calibrated when hot. The motors tend to be off at the bottom and top of their range, but generally it is assumed they are within 10 %. Therefore it is possible to operate without flowmeter feedback (open loop).

In general, a PWM output is used to drive a positive displacement pump. Therefore, the Flow will stay approximately the same, no matter how many Sections are on or off, but the pressure will change. It is assumed the pump is linear and will generate the same flow for any given PWM even with some sections off.

When in Open Loop there is no flowmeter feedback so the console simply computes a theoretical PWM based on ground speed. When in AUTO control, the Console automatically adjusts the PWM output to maintain the Target Rate as the speed changes or sections are turned on and off.

When ground speed is increased or decreased so far that the calculated PW (pulse width) exceeds the MIN PW or MAX PW, the actual PWM output will stay at MIN or MAX PW and the Red Warn Light will flash indicating over or under application. The RATE position will also begin to display the calculated application rate rather than just displaying the target rate. This will help indicate the amount of over or under application due to excessive or inadequate ground speed. The actual PWM output will continue to be clamped at the MIN or MAX PW until the ground speed returns to normal range.

In general (except for conditions noted above):

- RATE position will simply display the target rate since there is no means to measure the actual rate.
- The Red Warn Light will not be lit except when the PWM reaches the MIN PW or MAX PW setting.
- VOLUME/MINUTE will display the theoretical (not actual) flow at the calculated target application rate. Likewise the VOLUME counters and TANK level are also based off of this ‘simulated’ flow rate.
- The CONTROL RESPONSE setting is not used and can be left at the default (or any) setting

Appendix H - Pulse Width Modulation (PWM) Live Calibrate

LIVE CALIBRATE is only used in PWM Drive. See “SPECIAL” CALIBRATE for information on setting the output to PWM and selecting Open or Closed Loop operation.

If the user already knows the FLOW @ MIN PW, MIN PW, FLOW @ MAX PW and MAX PW factors, they can be entered directly in “SPECIAL CALIBRATE”. However if those factors are unknown then the interactive **LIVE CALIBRATE** is used to determine the correct value for each. *See figure 32.*

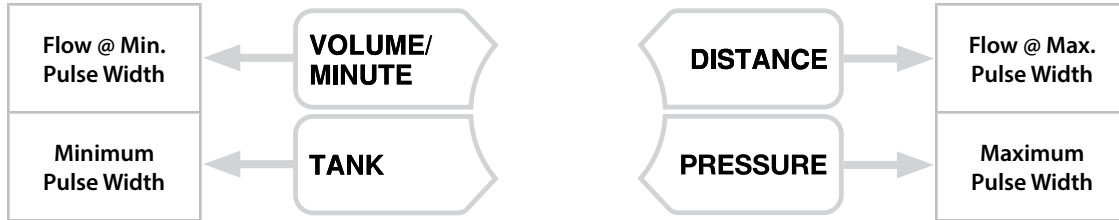

Figure 32

THE FOLLOWING APPLIES TO BOTH CLOSED AND OPEN LOOP OPERATION.

If DRIVE TYPE is set to PWM and the console is unlocked and in HOLD (or all non-zero width sections Off) and no ground speed is present and not in CALIBRATE or SPECIAL CALIBRATE, then holding the **Increase and Decrease** buttons for 1 second will enter LIVE CALIBRATE and the V and CAL icons and the Warning LED will turn on. *See figure 33.*



Figure 33

Once LIVE CALIBRATE is started, it will remain in LIVE CALIBRATE regardless of Speed or HOLD status.

LIVE CALIBRATE is exited and the factors saved by holding the **Increase/Decrease** buttons for 1 second regardless of section, Speed or HOLD status.

Factors will NOT be saved if power is lost, so unwanted changes can be discarded by removing power.

The display will show ---- when in an unused position but the V and CAL icons will remain on.

PWM output drive will be set to Minimum PWM duty cycle when in the two “min” (left) positions and will be set to Maximum PWM when in the two “max” (right) positions (*see figure 32 above*).

When in one of the four **USED** positions, momentarily pressing the **CAL** button will toggle the Pump on and off (at the selected MIN PW or MAX PW rate).

The pump is always turned off, in all **UNUSED** positions, or if all non-zero width sections are turned off. If all sections are turned off, then the pump will turn off but it will turn back on as soon as a section is turned on. However, if an unused

In **Closed Loop**, **LIVE CALIBRATE** allows the user to adjust the Min or Max PW factor and then immediately see how that affects the Flow at Min or Max PW, without the need to repeatedly enter and exit “SPECIAL” CALIBRATE.

In **Open Loop**, a flowmeter is not available to measure the flow so **LIVE CALIBRATE** provides a convenient 30 second timer and automatic section shut off to make it easier to capture the flow in a calibrated container to manually determine the flow.

position is selected then the pump is “toggled off” (as if the **CAL** button was used) and it will stay off even when a used position is selected. Normally all nonzero width sections should be turned on but the user may be setting up for special conditions where only some of the sections will be used. Turning all sections off can be used as an emergency off, as well as toggling the pump off with the **CAL** button.

Whenever FLOW @ MIN PW or FLOW @ MAX PW is being displayed it will always be displayed with two decimal places so the operator can see all digits of the value that will be stored, just like using “SPECIAL” CALIBRATE (0.01 to 655.35).

NOTE: The following pages give details on the operation and adjustments when in Closed or Open Loop Operations.

Appendix H - Pulse Width Modulation (PWM) Live Calibrate

Closed Loop Operation

In Closed Loop operation, a flowmeter is available to measure the flow so all four calibrate factors can be programmed interactively using the following procedure.

NOTE: LIVE CALIBRATE is only used in PWM Drive. If the Console does not display "PULSE" during power up, this procedure does not apply.

1. Park the applicator in a safe location and configure the sections as required for application.
2. Make sure all sections have the correct nozzles installed.
3. Fill applicator with water. **NOTE:** All counters including Volume and Tank will not count (change) during this procedure.
4. Remain parked, unlock the console, place it in Hold (or turn all sections off) and hold the **Increase/Decrease** buttons for 1 second. This will start **LIVE CALIBRATE** and the V and CAL icons and the Warning LED will turn on. *See figure 34.* The pump will remain off until the **CAL** button is pressed.



Figure 34

5. Turn all section switches that will be used on. The Hold input is ignored during this procedure so it can be left in either RUN or HOLD position.

MINIMUM SETTINGS - Skip Steps 6 through 9 if the Minimum settings are already correct.

6. Select the **FLOW @ MIN PW** (Volume/Minute) or the **MIN PW** (Tank) rotary position.
7. Press the **CAL** button and the pump will begin to run at the default or last set MIN PW rate. **FLOW @ MIN PW** (Volume/Minute) position will display the measured flow in Gallons/Minute and **MIN PW** (Tank) position will show the PWM duty cycle (0 to 100%). This allows the PWM output to be adjusted while observing the change in flow rate. To stop spraying simply press the **CAL** button again (but it will continue to display the last used **FLOW @ MIN PW** or **MIN PW**).
8. While running, press the **Increase/Decrease** buttons to adjust the pump speed until the desired minimum flow rate, or minimum pressure, or minimum RPM, or minimum PWM duty cycle is reached. The user may want to adjust the rate until it matches the minimum flow for the nozzles installed (minimum pressure), or adjust it until it reaches the lower limit of the Hydraulic drive. During this adjustment the pump can be toggled on and off as desired using the **CAL** button and the rotary switch can be changed between **FLOW@MIN PW** (Volume/Minute) or the **MIN PW** (Tank) as desired. The **Increase/Decrease** buttons have no effect when the pump is turned off (via **CAL** button or section switches) so neither Cal factor can be changed without the other being updated. This keeps **MIN PW** and **FLOW@MIN PW** in sync with each other during **LIVE CALIBRATE**. To make adjustments to just one factor without affecting the other, then "SPECIAL" CALIBRATE should be used, instead of **LIVE CALIBRATE**.

9. When satisfied with the minimum flow rate and minimum PWM then press the **CAL** button to toggle the pump off. If desired, the **FLOW @ MIN PW** and **MIN PW** can be written down for future reference.

MAXIMUM SETTINGS - Skip Steps 11 through 14 if the Maximum settings are already correct.

10. Change the rotary to **FLOW @ MAX PW** (Distance) or the **MAX PW** (Pressure) position.
11. Press the **CAL** button and the pump will begin to run at the default or last set **MAX PW** rate. **FLOW @ MAX PW** (Distance) position will display the measured flow in Gallons/Minute and **MAX PW** (Pressure) position will show the PWM duty cycle (0 to 100%). This allows the PWM output to be adjusted while observing the change in flow rate. To stop spraying simply press the **CAL** button again (but it will continue to display the last used **FLOW @ MAX PW** or **MAX PW**).
12. While running, press the **Increase/Decrease** buttons to adjust the pump speed until the desired maximum flow rate, or maximum pressure, or maximum RPM, or maximum PWM duty cycle is reached. The user may want to adjust the rate until it matches the maximum flow for the nozzles installed (maximum pressure), or adjust it until it reaches the upper limit of the Hydraulic drive. During this adjustment the pump can be toggled on and off as desired using the **CAL** button and the rotary switch can be changed between **FLOW @ MAX PW** (Distance) or the **MAX PW** (Pressure) as desired. The **Increase/Decrease** buttons have no effect when the pump is turned off (via **CAL** button or section switches) so neither Cal factor can be changed without the other being updated. This keeps **MAX PW** and **FLOW @ MAX PW** in sync with each other during **LIVE CALIBRATE**. To make adjustments to just one cal factor without affecting the other, then the "SPECIAL" CALIBRATE should be used, instead of **LIVE CALIBRATE**.
13. When satisfied with the maximum flow rate and maximum PWM then press the **CAL** button to toggle the pump off. If desired, the **FLOW @ MAX PW** and **MAX PW** can be written down for future reference.

STORE SETTINGS

14. If desired, the Minimum settings can be changed again by repeating steps 6 to 9 or the maximum settings can be changed by repeating steps 10 to 13. When satisfied with all four factors, press the **Increase/Decrease** buttons for 1 second to exit **LIVE CALIBRATE** and store all four factors. To abort any changes to the factors simply turn the power off.

NOTE: It is recommended (see Step 9 and 13), but not required, to turn the Pump off before switching between minimum and maximum factors. When an unused position is selected (displays dashes) the Pump will turn off automatically and when a minimum or maximum factor is selected again the pump can be toggled on again. Data collected while in a minimum or maximum position will be retained (even when a new position is selected), but it will not be stored until the user exits **LIVE CALIBRATE**.

Appendix H - Pulse Width Modulation (PWM) Live Calibrate Open Loop Operation

In Open Loop operation, a flowmeter is not available to measure the flow so a calibrated container must be used to measure the actual flow using the following procedure.

1. Park the applicator in a safe location and configure the sections as required for application.
2. Make sure all sections have the correct nozzles installed.
3. Fill applicator with water. NOTE: all counters including Volume and Tank will not count (change) during this procedure.
4. Remain parked, unlock the console, place it in Hold (or turn all Sections off), and hold the **Increase/Decrease** buttons for 1 second. This will start LIVE CALIBRATE and the V and CAL icons and the Warning LED will turn on. The pump will remain off until the **CAL** button is pressed.
5. Turn all section switches on (or the section switches that will be used). The Hold input is ignored during this procedure so it can be left in either Run or Hold position.

MINIMUM SETTINGS

Skip Steps 6 through 14 if the Minimum settings are already correct.

6. Select the **MIN PW** (Tank) rotary position. The **FLOW @ MIN PW** (Volume/Minute) position cannot be used because no flowmeter is available to measure the flow.
7. Press the **CAL** button and the pump will begin to run at the default or last set **MIN PW** rate and it will display MIN PW (0 to 100%). To stop spraying simply press the **CAL** button again (but it will continue to display the MIN PW).
8. While running, press the **Increase/Decrease** buttons to adjust the pump speed until the desired minimum pressure (using an external Pressure Gauge), or minimum RPM (using an external RPM Indicator), or minimum PWM duty cycle (displayed on console) is reached. The user may want to adjust the rate until it matches the minimum flow for the nozzles installed (minimum pressure), or adjust it until it reaches the lower limit of the Hydraulic drive. During this adjustment the pump can be toggled on and off as desired using the **CAL** button but the rotary switch should not be changed to the **FLOW @ MIN PW** position because that starts a 30 second Timer. If the **FLOW @ MIN PW** position is accidentally selected then returning to the **MIN PW** (Tank) position will reset the Timer. The **Increase/Decrease** buttons will still change MIN PW even with the pump turned off.
9. When satisfied that MIN PW has been set correctly then press the **CAL** button to toggle the pump off. If desired, the MIN PW can be written down for future reference.
10. Place a calibrated container under one of the nozzles, or for maximum accuracy, capture all the flow from all the nozzles.
11. Select the **FLOW @ MIN PW** (Volume/Minute) position. This will enable a 30 second Timer when the pump is started, and it will display 30.
12. Press the **CAL** button and the pump will begin to run at the previously set MIN PW rate and the display will show a 30 second timer that counts down. When it reaches zero it will automatically stop the pump and begin to display **FLOW @ MIN PW**. The 30 second run can be aborted by pressing the **CAL** button or by changing the rotary to the **MIN PW** (Tank) position or an unused position. This will reset the 30 second timer so it can be started over, after emptying the calibrated containers.
13. Use volume collected in the calibrated container to compute **FLOW @ MIN PW** as follows * If the flow from all nozzles was collected then convert it to gallons (or liters). * If the flow from a single nozzle was collected then multiply it times the number of nozzles and convert it to gallons (or liters).

NOTE: * Compute FLOW @ MIN PW = Gallons/0.5 or Liters /0.5.

14. Use the **Increase/Decrease** buttons to adjust the **FLOW @ MIN PW** to the value computed above. Be sure to complete this step before changing the rotary position since any changes will reset the 30 second timer and prevent changes to **FLOW @ MIN PW**.

MAXIMUM SETTINGS

Skip Steps 15 through 23 if the Maximum settings are already correct.

15. Select the **MAX PW** (Pressure) rotary position. The **FLOW @ MAX PW** (Distance) position cannot be used because no flowmeter is available to measure the flow.
16. Press the **CAL** button and the pump will begin to run at the default or last used MAX PW rate and it will display MAX PW (0 to 100 %). To stop spraying simply press the **CAL** button again (but it will continue to display the MAX PW).
17. While running, press the **Increase/Decrease** buttons to adjust the pump speed until the desired maximum pressure (using an external Pressure Gauge), or maximum RPM (using an external RPM Indicator), or maximum PWM duty cycle (displayed on console) is reached. The user may want to adjust the rate until it matches the maximum flow for the nozzles installed (maximum pressure), or adjust it until it reaches the upper limit of the Hydraulic drive. During this adjustment the pump can be toggled on and off as desired using the **CAL** button but the rotary switch should not be changed to the **FLOW @ MAX PW** (Distance) position because that starts a 30 second Timer. If the **FLOW @ MAX PW** position is accidentally selected then returning to the **MAX PW** (Pressure) position will reset the Timer. The **Increase/Decrease** buttons will still change MAX PW even with the pump turned off.

Appendix H - Pulse Width Modulation (PWM) Live Calibrate Open Loop Operation

18. When satisfied that MAX PW has been set correctly, press the **CAL** button to toggle the pump off. If desired, the MAX PW can be written down for future reference.
19. Place a calibrated container under one of the nozzles, or for maximum accuracy, capture all the flow from all the nozzles.
20. Select the **FLOW @ MAX PW** (Distance) position. This will enable a 30 second Timer when the pump is started, and it will display 30.
21. Press the **CAL** button and the pump will begin to run at the default or last set MAX PW rate and the display will show a 30 second timer that counts down. When it reaches zero it will automatically stop the pump and begin to display FLOW @ MAX PW. The 30 second run can be aborted by pressing the **CAL** button or by changing the rotary switch to the **MAX PW** (Area/Hour) position or an unused position. This will reset the 30 second timer so it can be started over after emptying the calibrated containers.
22. Use volume collected in the calibrated container to compute FLOW @ MAX PW as follows * If the flow from all nozzles was collected then convert it to gallons (or liters). * If the flow from a single nozzle was collected then multiply it times the number of nozzles and convert it to gallons (or liters).

NOTE: * Compute FLOW @ MAX PW = Gallons/0.5 or Liters /0.5.

23. Use the **Increase/Decrease** buttons to adjust the FLOW @ MAX PW to the value computed above. Be sure to complete this step before changing the rotary position since any changes will reset the 30 second timer and prevent changes to FLOW @ MAX PW.

STORE SETTINGS

24. If desired, the Minimum settings can be changed again by repeating steps 7 to 14 or the maximum settings can be changed by repeating steps 15 to 23. When satisfied with all four factors, turn rotary dial to Speed, and press the **Increase/Decrease** buttons for 1 second to exit LIVE CALIBRATE and store all four factors. To abort any changes to the factors simply turn the power off.

NOTE: For maximum accuracy the 30 second runs should not be disrupted by turning the pump off or by changing the rotary switch. However the CAL button or rotary switch or a section switch can be used for an emergency stop situation.

Appendix I - Pressure Based Control

Enabling

SprayMate™ Plus can be configured for Pressure Based Control by entering Calibration and adjusting the **Flow Cal** number to 0. In addition, MIN FLOW and MIN PRESSURE parameters must also be set or the system will not operate. The MIN PRESSURE parameter is only visible and accessible when Pressure Based Control has been enabled; MIN FLOW is also used in flowmeter based control.

1. Adjust FLOW CAL value to 0 to enable Pressure Based Control.
2. Switch to MIN FLOW position. Number 1 visible indicates adjustment of MIN FLOW value.
3. Adjust value to the recommended minimum flow rating for your nozzles multiplied by the total number of nozzles.
4. Press and release CAL button. Number 2 visible indicates adjustment of MIN PRESSURE parameter.
5. Adjust value to the recommended minimum pressure rating for your nozzles.
6. Press and hold CAL button to save settings and exit Calibration.

Operation

When operating in Pressure Based Control, the system will calculate flow and totals based only on readings from the pressure sensor. Refer to Special Calibration settings on page 25 to adjust parameters for accurate Pressure Based Control.

Appendix J - Default Calibration Values

<i>Calibration Factor</i>	<i>English</i>	<i>Metric</i>	<i>Turf</i>
Width: Section 1	180 in.	4.6 m	180 in
Width: Section 2	180 in.	4.6 m	0
Width: Section 3	180 in.	4.6 m	0
Speed Cal	0.189 (in/edge)	0.48 (cm/edge)	0.189 (in/edge)
Control Speed	-1	-1	-1
<i>Test Speed</i>	n/a	n/a	n/a
Target Rate	20.00 Gal/Acre	100.00 liters/ha	2.00 Gal/1000 Ft ²
Adjust Rate	1.00 Gal/Acre	10.00 liters/ha	0.10 Gal/1000 Ft ²
Min Flow	0.0 (Off)	0.0 (Off)	0.0 (Off)
Flow Cal (Edges/Gal)	145.0	145.0	145.0

<i>Special Calibration Factor</i>	<i>Page</i>	<i>English</i>	<i>Metric</i>	<i>Turf</i>
Units	1	Eng	Met	Turf
Material	1	H ₂ O	H ₂ O	H ₂ O
Output Drive: PULSE or Std	1	Std	Std	Std
Application ID	1	1	1	1
Start Speed	1	0 MPH (off)	0 km/h (off)	0 MPH (off)
Start Speed Time	1	0	0	0
Tank Alarm Level	1	Off	Off	Off
Tank Fill Level	1	Off	Off	Off
Pressure Offset	2	0 psi	0 bar	0 psi
Pressure Alarm Low	2	0 psi (off)	0 bar (off)	0 psi (off)
Pressure Alarm High	2	0 psi (off)	0 bar (off)	0 psi (off)
Pressure Full Scale (Pressure Mode)	2	150 psi	150 psi	150 psi
Auto Delay Time	2	1 Sec.	1 Sec.	1 Sec.
Valve Start % (PWM) Auto Shut-off (STD)	2	10 0 (Off)	10 0 (Off)	10 0 (Off)
Start Time	2	0 (Off)	0 (Off)	0 (Off)
Hold Input Polarity	2	Closed	Closed	Closed
Multifunction Flow Trigger Threshold	3	15.0 gal/min	60.0 liters/min	4.0 gal/min
Multifunction Output	3	Master	Master	Master
Flush Delay Time	3	3 s	3 s	3 s
Flush Time	3	5 s	5 s	5 s
Audible Alarm Enable	3	On	On	On
Minimum Speed Alarm	3	0 MPH	0 kph	0 MPH
Serial VRA Protocol	3	Micro-Trak	Micro-Trak	Micro-Trak
Manual Control Enable	3	On	On	On
PWM Frequency (PWM)	4	200 Hz	200 Hz	200 Hz
Flow @ MAX PW (PWM)	4	.00	.00	.00
Maximum PW (PWM)	4	90%	90%	90%
Closed / Open Loop (PWM)	4	Closed Loop	Closed Loop	Closed Loop
Agitation % (PWM) Valve Polarity (STD)	4	0 (Off) Bypass	0 (Off) Bypass	0(Off) Bypass
Minimum PW (PWM)	4	10%	10%	10%
Flow @ MIN PW (PWM)	4	.00	.00	.00
FTW Mode	4	Off	Off	Off
Rate Alarm Threshold	5	10%	10%	10%
Section Input Polarity	5	12v	12v	12v
Fixed Minimum Flow	5	0.0 (off)	0.0 (off)	0.0 (off)

Appendix K - Radar Adapter Cables

Vansco Radar Amp Connector

P/N 14926



DICKEY-john Radar Amp Connector

P/N 14812

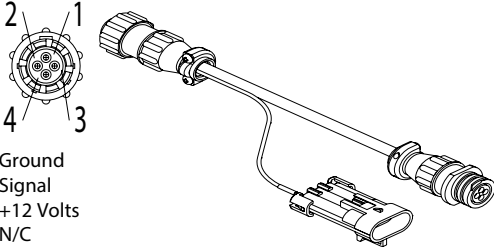

1. Ground
2. Signal
3. +12 Volts
4. N/C

DICKEY-john Radar Cannon Connector

P/N 14813

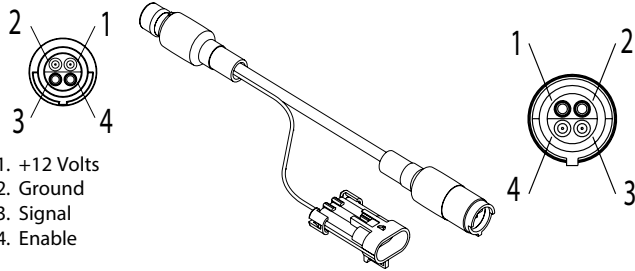

1. +12 Volts
2. Ground
3. Signal
4. Enable

DICKEY-john Radar Deutsch Connector

P/N 14814

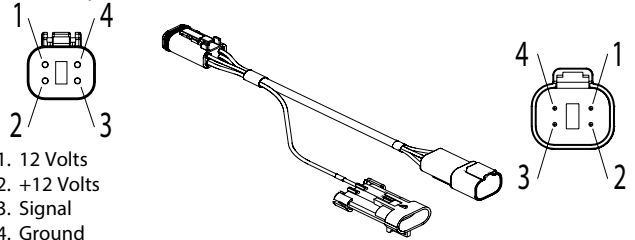

1. 12 Volts
2. +12 Volts
3. Signal
4. Ground

DICKEY-john Radar Ford Connector

P/N 14816

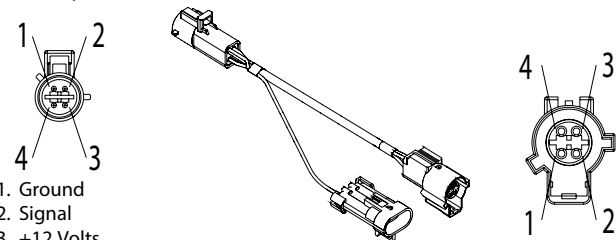

1. Ground
2. Signal
3. +12 Volts
4. Enable

DICKEY-john Radar Packard Connector

P/N 14815

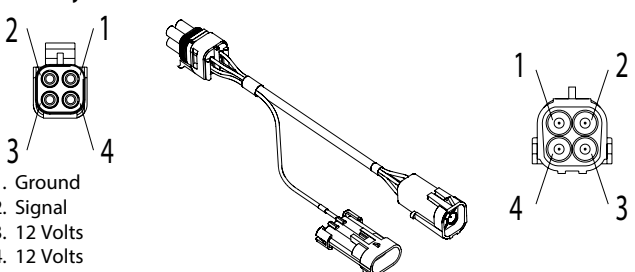

1. Ground
2. Signal
3. 12 Volts
4. 12 Volts

In-Cab Case MX Series Britax Connector

P/N 18319

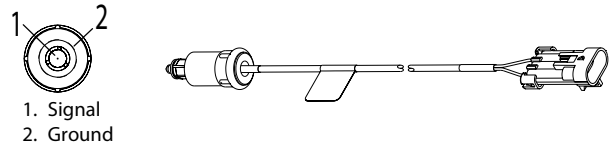

1. Signal
2. Ground

In-Cab John Deere Metri-Pack Connector 8000/9000 Series

P/N 14810

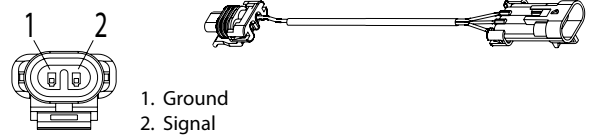

1. Ground
2. Signal

In-Cab John Deere 1-pin M/P 280

P/N 18041

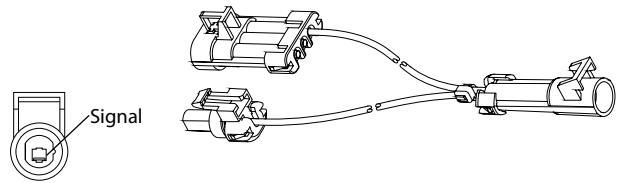

In-Cab John Deere 30 Series 7-pin Amp

P/N 17811

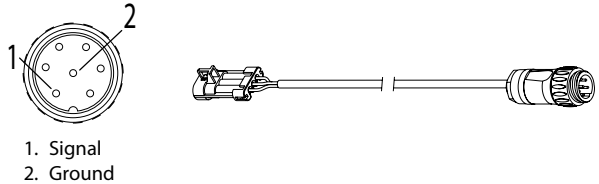

1. Signal
2. Ground

In-Cab John Deere "Y" Connector

P/N 14811

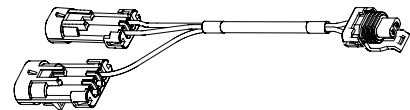

Magnavox & Phillips Radar Packard Connector

P/N 14818

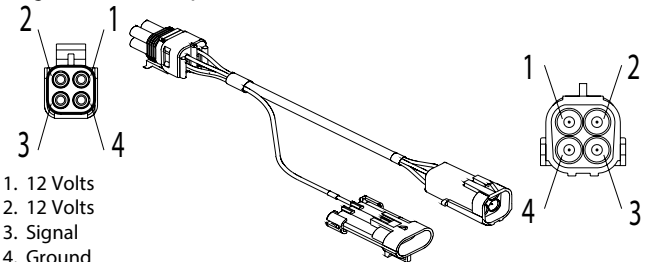

1. 12 Volts
2. 12 Volts
3. Signal
4. Ground

Raven Radar Conxall Connector

P/N 14817

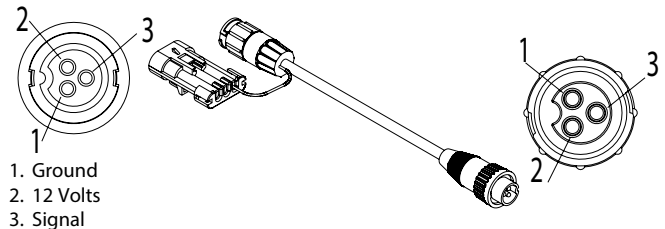

1. Ground
2. 12 Volts
3. Signal

Appendix L - Conversion Chart

English to Metric

When You Know	Multiply By	To Find
LINEAR MEASUREMENT		
inches	25.4	millimeters
feet	0.305	meters
yards	0.914	meters
miles	1.61	kilometers
LAND MEASUREMENT		
square inches	645.16	square millimeters
square feet	0.093	square meters
square yards	0.836	square meters
acres	.405	hectares
square miles	2.59	square kilometers
LIQUID MEASUREMENT		
fluid ounces	29.57	milliliters
pint	0.473	liters
quart	0.946	liters
gallons	3.785	liters
VOLUME		
cubic feet	0.028	cubic meters
cubic yards	0.765	cubic meters
DRY MEASUREMENT		
quart	1.101	liters
peck	8.810	liters
bushel	35.239	liters
FUEL CONSUMPTION		
10 miles per gallon = 4.25 kilometers per liter		

Metric to English

When You Know	Multiply By	To Find
LINEAR MEASUREMENT		
millimeters	.039	inches
meters	3.28	feet
meters	1.09	yards
kilometers	.62	miles
LAND MEASUREMENT		
square millimeters	0.00155	square inches
square meters	10.764	square feet
square meters	1.195	square yards
hectares	2.47	acres
square kilometers	0.386	square miles
LIQUID MEASUREMENT		
milliliters	0.034	fluid ounces
liters	0.529	pint
liters	0.264	quart
liters	2.64	gallons
VOLUME		
cubic meters	35.314	cubic feet
cubic meters	1.307	cubic yards
DRY MEASUREMENT		
liters	1.101	quart
liters	8.810	peck
liters	35.239	bushels
FUEL CONSUMPTION		
10 kilometers per liter = 23.5 miles per gallon		

Conversion Abbreviations

Symbols	Symbols	Symbols
in. = inches	pt. = pint	km = kilometers
ft. = feet	qt. = quart	mm ² = square millimeters
yd. = yards	gal. = gallon	m ² = square meters
ml. = miles	ft ³ = cubic feet	ha = hectares
in ² = square inches	yd ³ = cubic yards	km ² = square kilometers
ft ² = square feet	pk. = peck	ml = milliliters
yd ² = square yards	bu. = bushel	l = liters
ml ² = square miles	mm = milliliters	dal = dekaliters (10 liters)
fl oz. = fluid ounces	m = meters	m ³ = cubic meters

Appendix M - Replacement Parts List

The following replacement parts are available from your dealer or distributor. A Dealer Locator can be found online at <http://www.micro-trak.com/where-to-buy/dealer-locator>.

PART NUMBER DESCRIPTION

01410	Astro II GPS Speed Sensor
01425	Astro 5 GPS Speed Sensor
01531	Speed sensor kit (magnetic)
01535	Remote run/hold sensor kit
01554	Gear tooth sensor kit (proximity sensor)
10013	Speed sensor mount bracket
12069	Magnet kit (6 magnets per kit)
12888	Console mount knob
12889	Console mount washer
12910	14" Black plastic cable ties (bag of 10)
13096	5-foot Hall-effect Speed/Flow Sensor Cable
13181	Console mount kit*
13226	5' remote run/hold sensor cable
14315	Power cable
17539	Servo to PWM valve adapter cable
18700	SprayMate Plus Console
18541	Implement Whisker Switch kit w/magnetic mount
18280	Branch Harness - Weather Pack Shroud connectors
18532	Branch Harness - Weather Pack Tower connectors
18754	Plus Series Single Pressure Sensor Cable 15'
18756	6-pin M/P Extension Cable 10'
18757	Pressure Sensor - 150 psi max.
18758	Pressure Sensor - 300 psi max.
18764	Plus Series Single Pressure Sensor Harness Kit
18770	SprayMate Plus Reference Manual
21778	Run/Hold Switch Kit
21779	Power Switch Kit

*The Console Mount Kit is available only as a kit, some parts are not available in individual components. Parts and design specifications subject to change without notice.

Optional 2-Pin, 3-Pin and 10-Pin Metri-Pack 150 extension cables:							
Part No.	M/P 2-Pin	Part No.	M/P 3-Pin	Part No.	M/P 5/5 10-Pin	Part No.	W/P 3-Pin
13200	5-foot	13205	5-foot	14363	5-foot	10450	5-foot
13201	10-foot	13206	10-foot	14316	10-foot	10449	10-foot
13202	15-foot	13207	15-foot	14317	15-foot	10876	15-foot
13203	20-foot	13208	20-foot	14364	20-foot	10829	20-foot
13204	25-foot	13209	25-foot	14365	25-foot	11462	25-foot
		13419	50-foot	14419	50-foot		

Appendix N - Electric Motor Driver - Setup & Connectivity

This appendix features the PN01758 40A PWM EMD kit. Information on other models can be found online at: www.micro-trak.com/product/electric-motor-driver/.

40A PWM Electric Motor Driver

The Electric Motor Driver (EMD) replaces the servo valve. System flow is controlled by regulating the pump speed via a PWM signal to the EMD.

NOTE: This unit will ONLY work with PWM (Pulse Width Modulated) Control drives. Set the PWM frequency of your controller to 150 Hz.

MODULE INSTALLATION

NOTE: The mounting surface must be cleaned so it is free from dirt, moisture and oil residues. Failure to clean the mounting surface may result in the EMD working loose.

Remove the GREEN backing from the Dual-Lock™ fasteners on the bottom of the EMD unit. Position the EMD where wiring will work the best. Extension cables are available. Firmly press the EMD into place. Secure the EMD to the equipment using plastic cable ties to prevent the EMD from coming into contact with moving parts if the Dual-Lock™ fasteners should work loose. If desired, the EMD can be fastened with screws, using the holes in the mounting flanges.

ELECTRICAL INSTALLATION

This section explains how to hook-up your EMD to a 12-volt power connection, and how to connect your EMD to your controller harness.

The EMD **MUST** be connected to a 12-volt DC negative ground electrical system.

POWER BATTERY CONNECTION

Locate the power cable, P/N 18419 and route to the battery. In routing cable avoid areas where the cable may be subjected to abrasion or excessive heat. Attach the BLACK wire to ground. See Illustration to the upper right. Be sure there is a good metal-to-metal contact. Connect the RED wire to the positive battery terminal.

Connect the power to the EMD by plugging the 2-Pin M/P 480 Tower on the power cable into the 2-Pin M/P 480 Shroud of the EMD module.

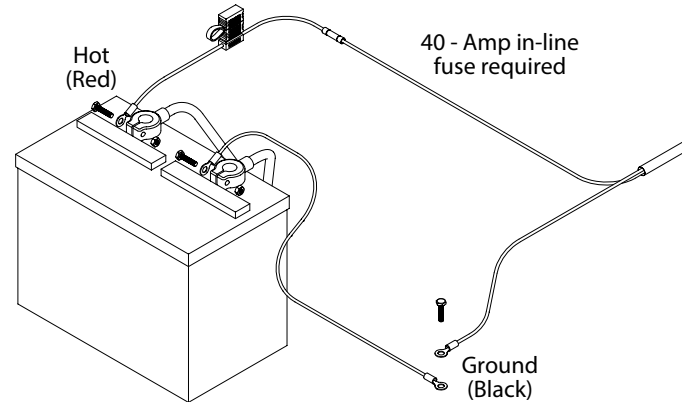

SIGNAL AND MOTOR CONNECTIONS

NOTE: Be sure to route cables away from sharp edges, areas of high heat and moving parts. Secure all cables firmly with plastic cable ties.

Connect the other end of the cable to the mating connector on the controller harness using Adapter Cable P/N 17539 if required.

Locate the pump cable P/N 18420. Plug the 2-pin M/P 480 Shroud into the 2-pin M/P 480 Tower on the EMD module. Connect the other end to the pump. Insure that the pump is running in the correct direction. If not, simply reverse the wires from the pump to the pump cable.

See Next Page for Applicable Diagram.

Appendix N - Electric Motor Driver - Setup & Connectivity

LED Codes & Module Diagram

System Status LED Indicator Codes

Single Status LED: flashing code repeats after pause - cycle controller power to clear fault code	
LED on steady	Unit turned on and operating normally
Steady Flashing	Unit in HOLD. Check Run/Hold switch or remote switch on controller.
1 Flash/pause	Open circuit detected. Check motor connections for open.
2 Flashes/pause	Output short circuit detected. Check motor connections.
3 Flashes/pause	Over-current condition. Check total load.
4 Flashes/pause	Input power fault. Check input voltage and/or power wiring.
5 Flashes/pause	PWM control input frequency out of range. Check settings.

⚠ Cycle power with controller ON/OFF switch to clear a fault code.

CONTROL SIGNAL LEDS function

1. LED lights when the PWM signal is present.
2. Becomes brighter when the signal is increasing and becomes dimmer when the signal is decreasing.

Module Diagram

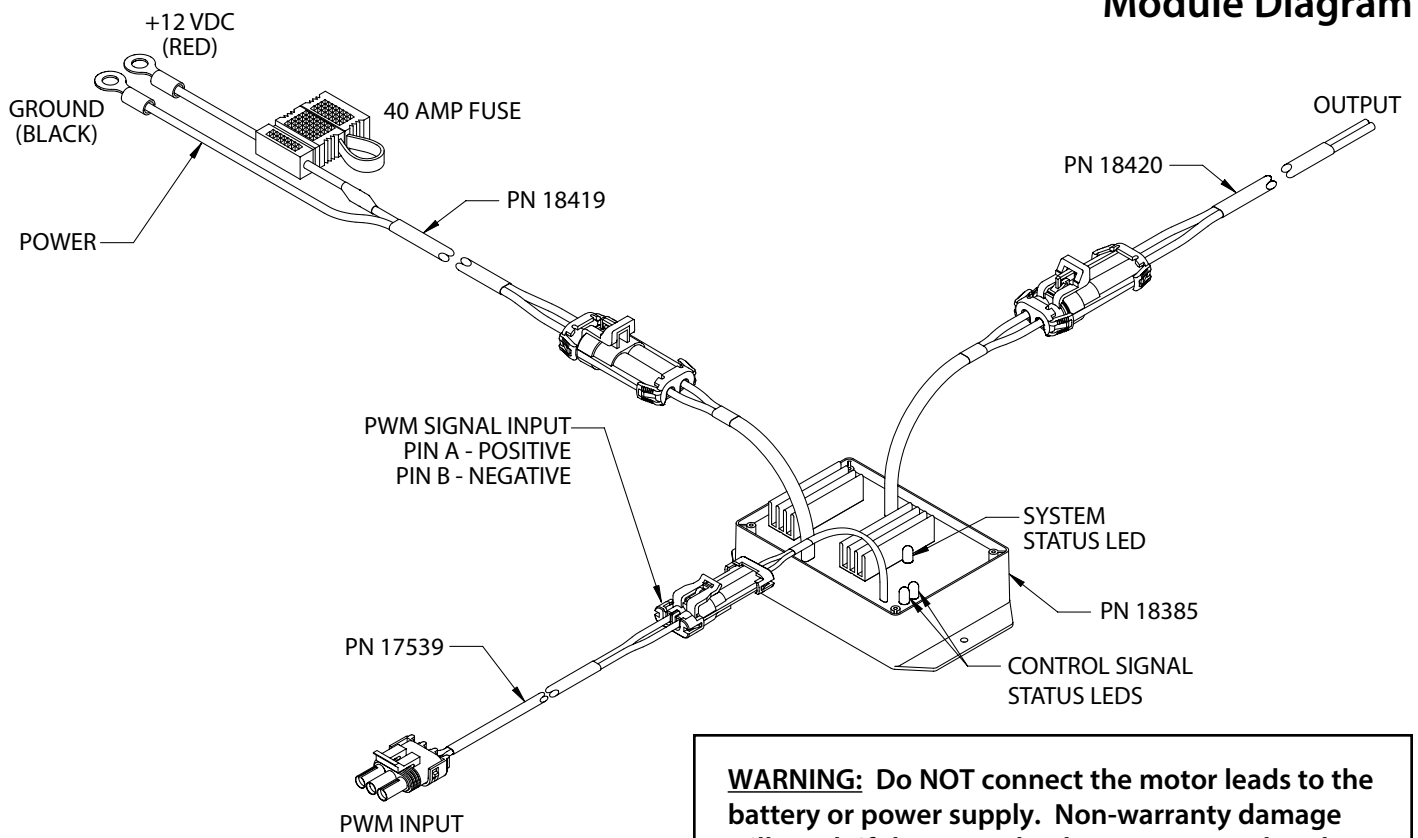

WARNING: Do NOT connect the motor leads to the battery or power supply. Non-warranty damage will result if the motor leads are connected to the battery or power supply.

Appendix N - Electric Motor Driver - Setup & Connectivity

System Diagrams

Single Pump System

Standard single pump system. The control signal from the SprayMate Plus connects to EMD input. EMD output controls pump.

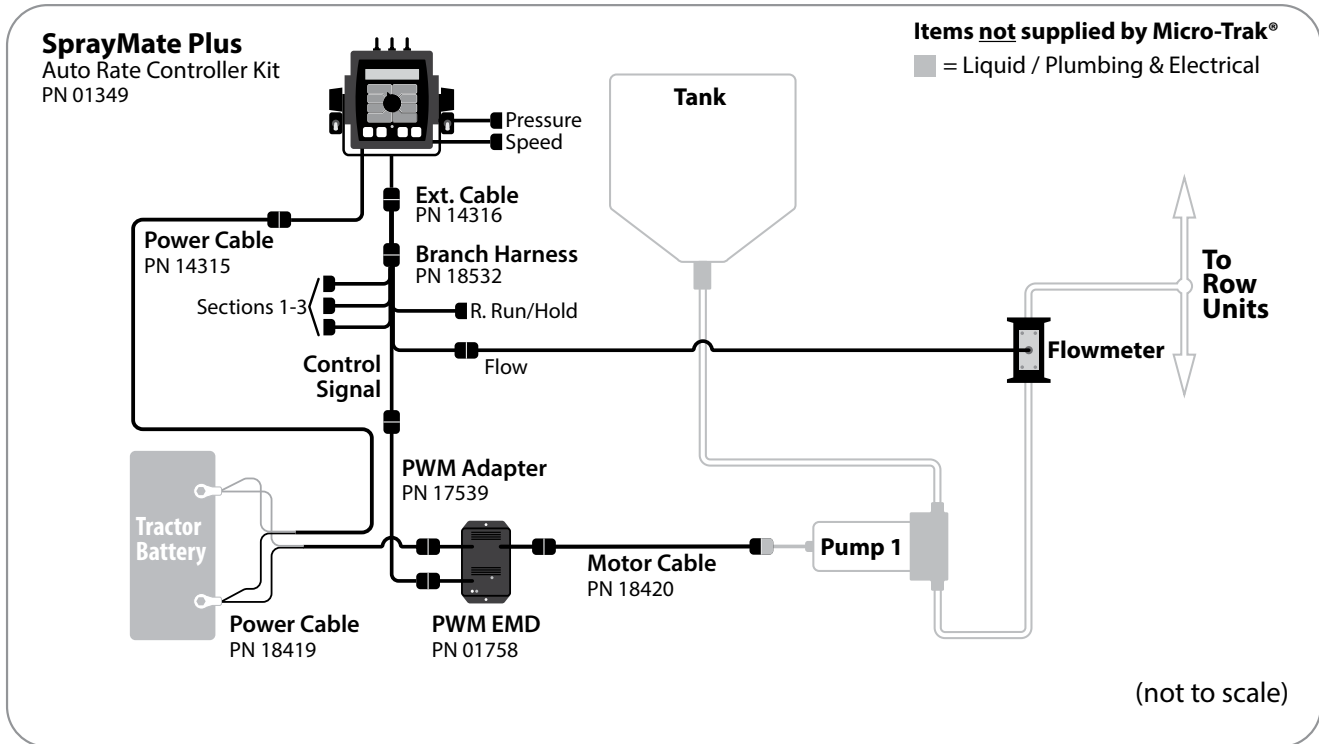

2 Pump System for expanded range

The control signal from the SprayMate Plus connects to EMD input. EMD output controls **Pump 1**. Multifunction output connects to PN18928 Relay Module to engage **Pump 2** on demand. Set Multifunction Output for F-FLO (Fixed Flow Trigger) and enter threshold value in Special Calibration.

Note: Micro-Trak offers a PN19963 2nd Motor EMD Enable & Motor Cable kit - includes PN18928 Relay Module & PN18420 Motor Cable.

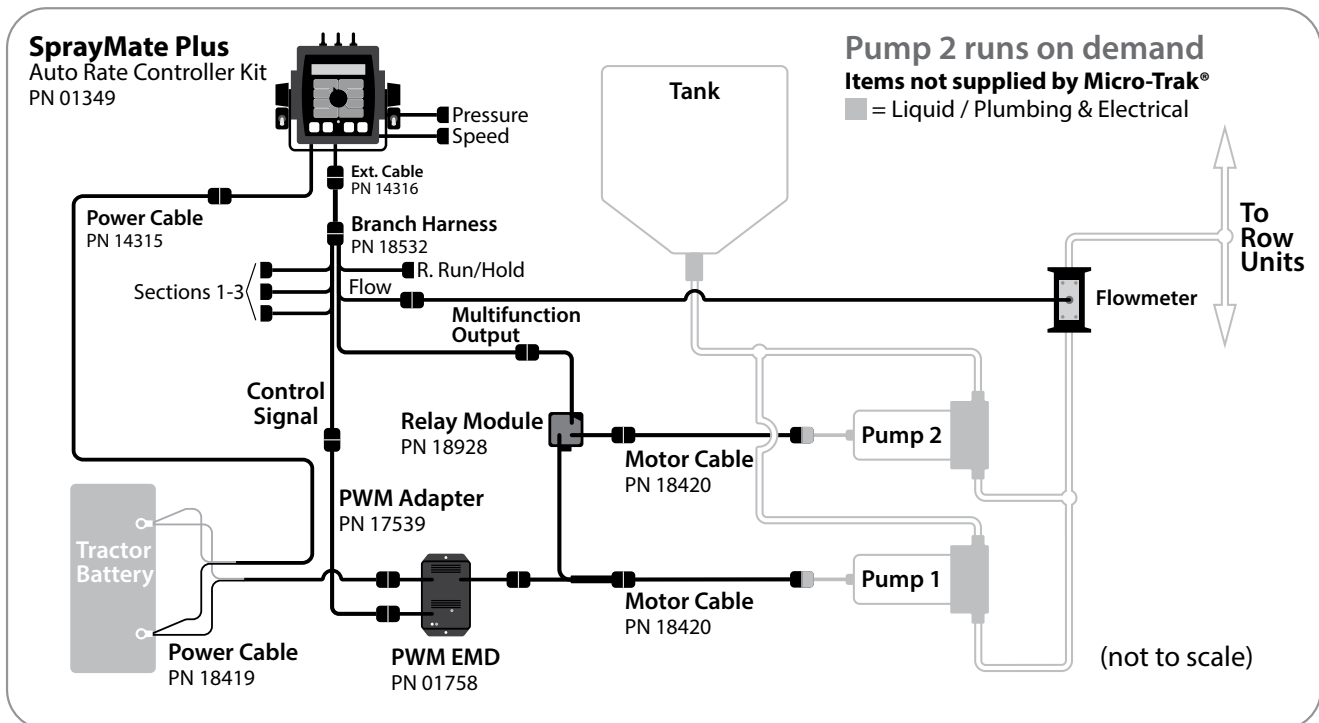



111 LeRay Ave. Eagle Lake, MN 56024-9650

Toll-Free: 800-328-9613

507-257-3600 • Fax 507-257-3001

www.micro-trak.com • email: trakmail@micro-trak.com